

BELL IN HAND TAVERN  
45 UNION STREET

UNION STREET

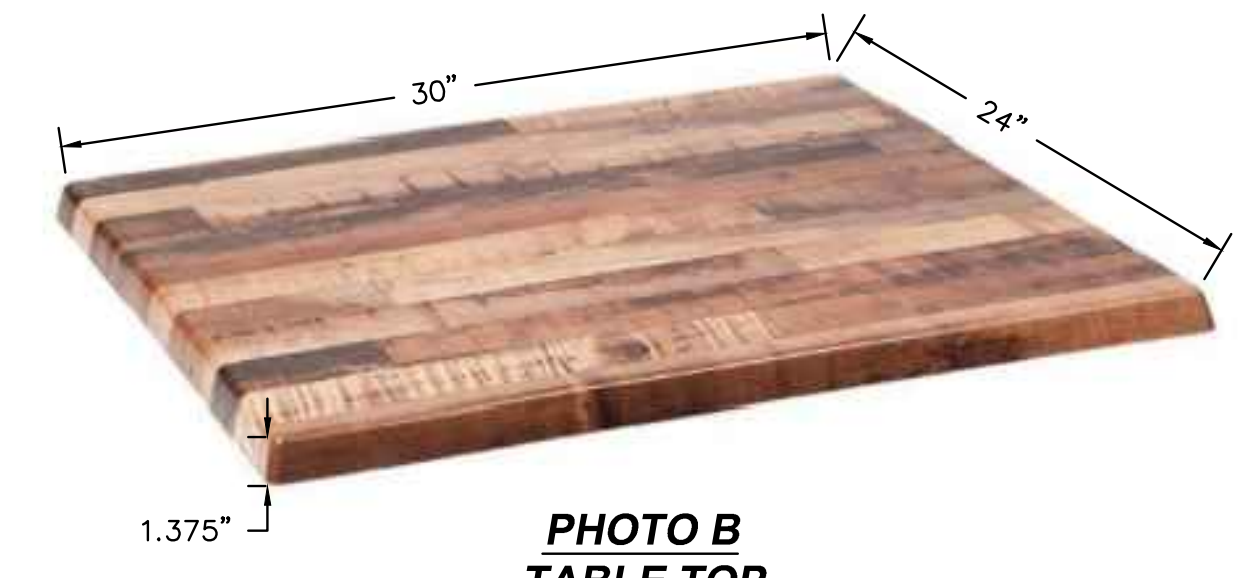
**SIDEWALK CAFE PLAN**  
SCALE: 1"=10'

**PROPOSED LEGEND**

	EXISTING CURB LINE
	PROPERTY LINE
TYP.	TYPICAL

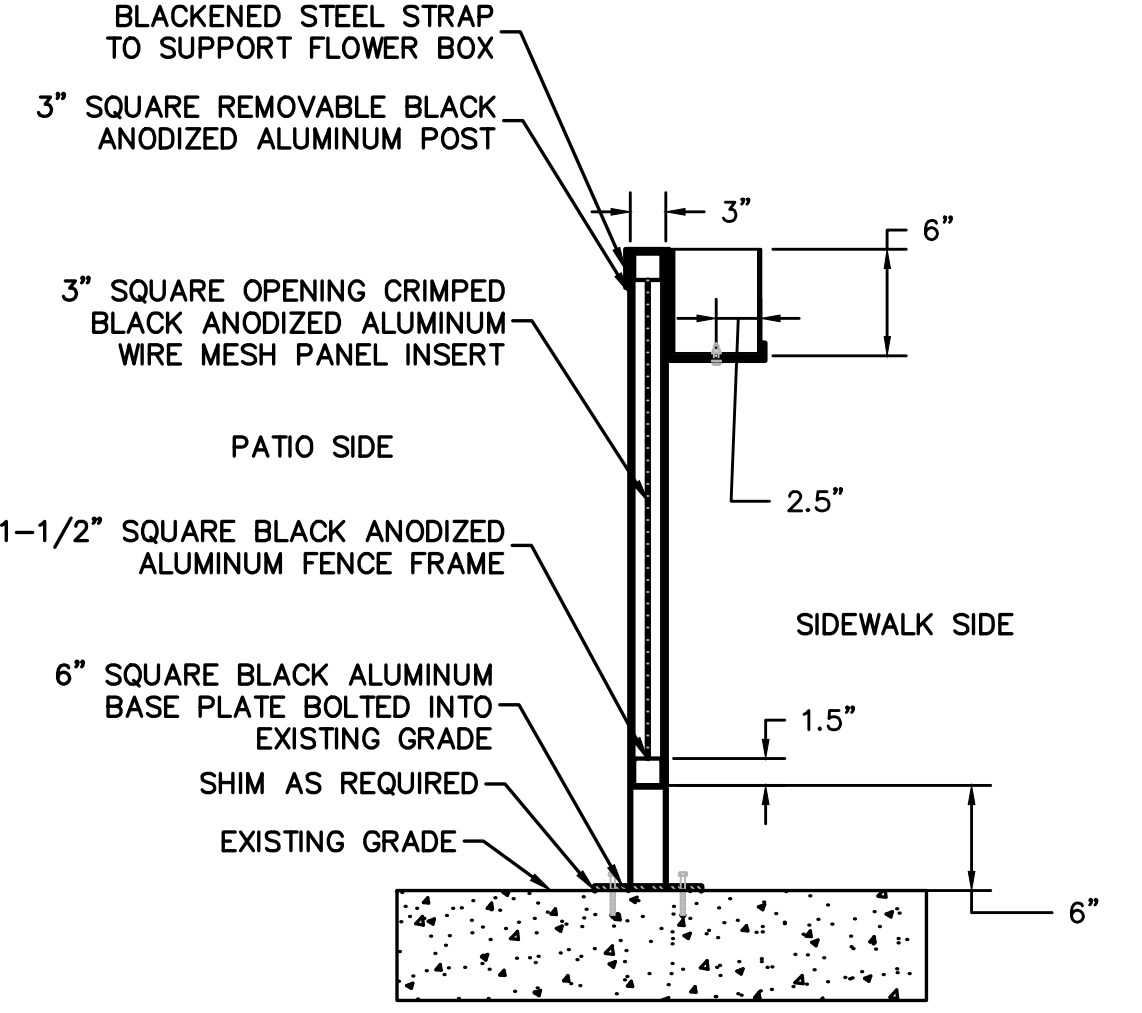


**PHOTO A**  
**ALUMINUM TABLE BASE**

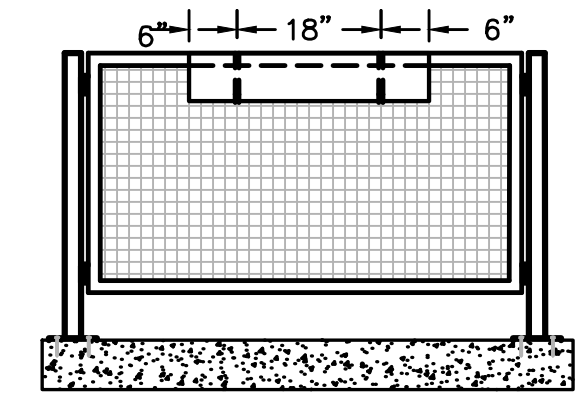


**PHOTO B**  
**TABLE TOP**

**ADA TABLE DIMENSIONS**  
30"x24"  
1.375" THICKNESS  
OVERALL HEIGHT: 31.375"



**SECTION AT REMOVABLE RAILING PANEL**  
NOT TO SCALE



**ELEVATION AT REMOVABLE RAILING PANEL**  
NOT TO SCALE

**DETAIL D**  
**REMOVABLE RAILING AND PANEL**



**PHOTO C**  
**ALUMINUM AND WOOD CHAIR**

CHECKED FOR GENERAL DESIGN AND CONFORMITY TO CITY STANDARDS

PUBLIC WORKS DEPARTMENT

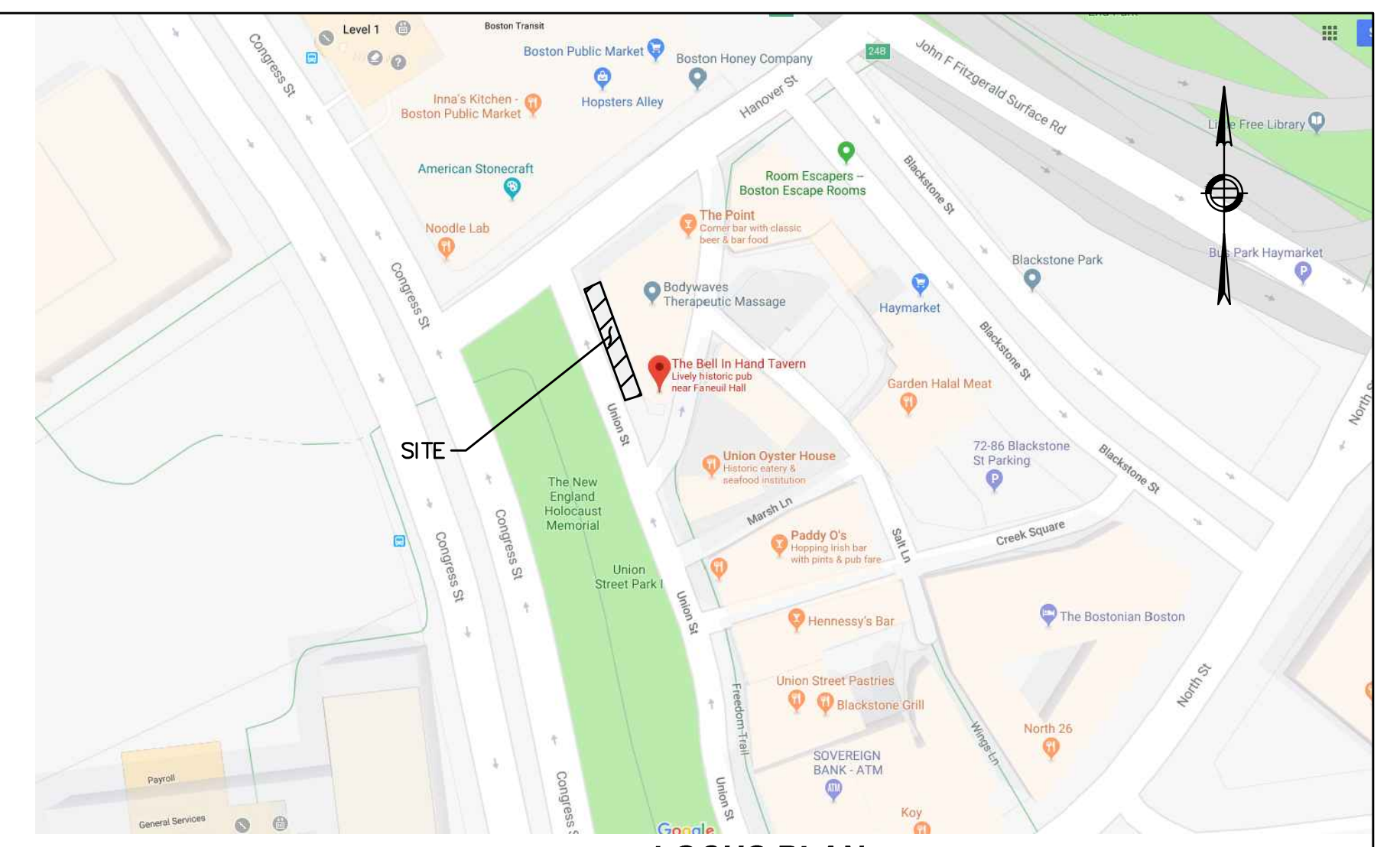
APPROVED

COMMISSIONER OF PUBLIC WORKS

PUBLIC IMPROVEMENT COMMISSION

CHIEF ENGINEER

JOHN M. SCHMID, P.E.  
MASSACHUSETTS REG. NO. 39155  
REGISTERED PROFESSIONAL ENGINEER



**LOCUS PLAN**  
NOT TO SCALE  
SOURCE: GOOGLE MAPS

FOR REGISTRY USE ONLY

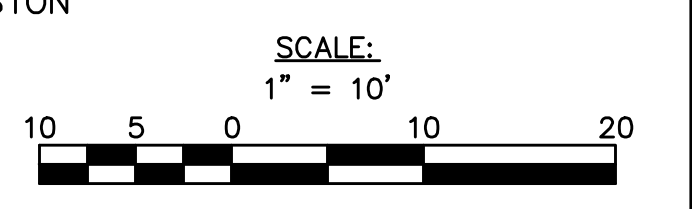
SHEET 1 OF 1  
PLAN SHOWING THE EXTERIOR SIDEWALK CAFE (48 SEATS)  
ON UNION STREET

CITY OF BOSTON PUBLIC WORKS DEPARTMENT  
ENGINEERING DIVISION  
SIDEWALK CAFE LICENSE PLAN

BELL IN HAND  
45 UNION STREET

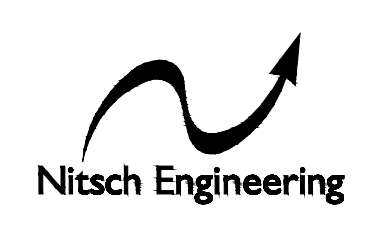
BOSTON

SCALE: HOR. 1" = 10'



DIVISION ENGINEER

JUNE 2018

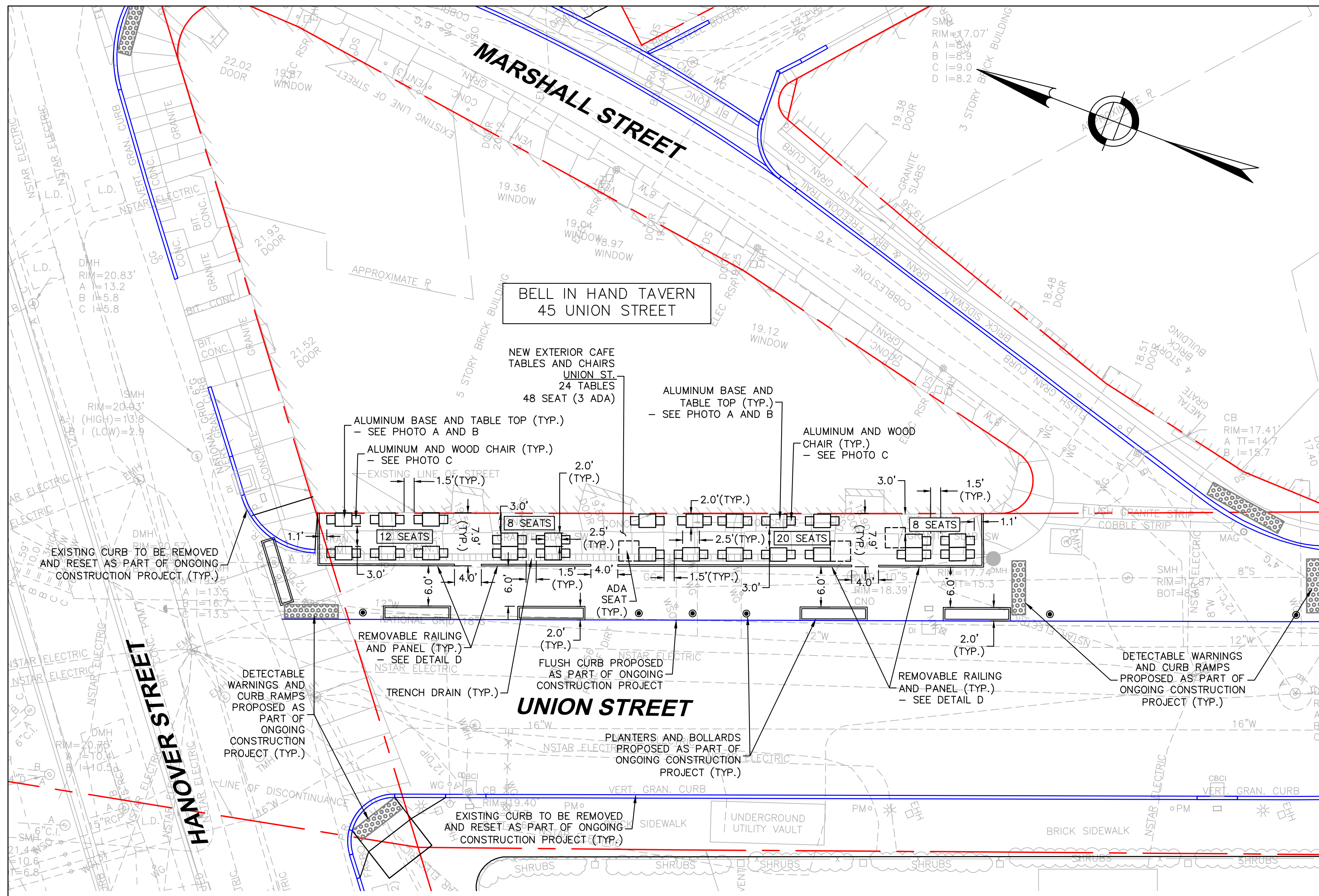


PREPARED BY:  
NITSCH ENGINEERING  
2 CENTER PLAZA, SUITE 430  
BOSTON, MA 02108  
PHONE: 617-338-0063

DESIGNED BY: PES  
DRAWN BY: PES  
CHECKED BY: JMS

NITSCH PROJECT NUMBER: 12948  
NITSCH FILE NAME: 12948 PIC

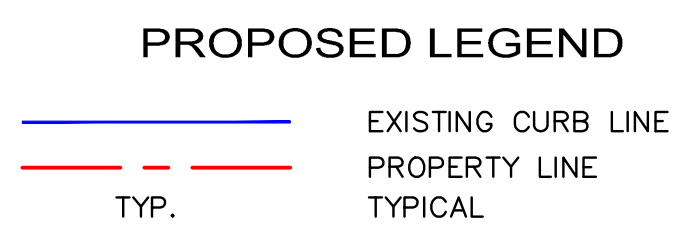




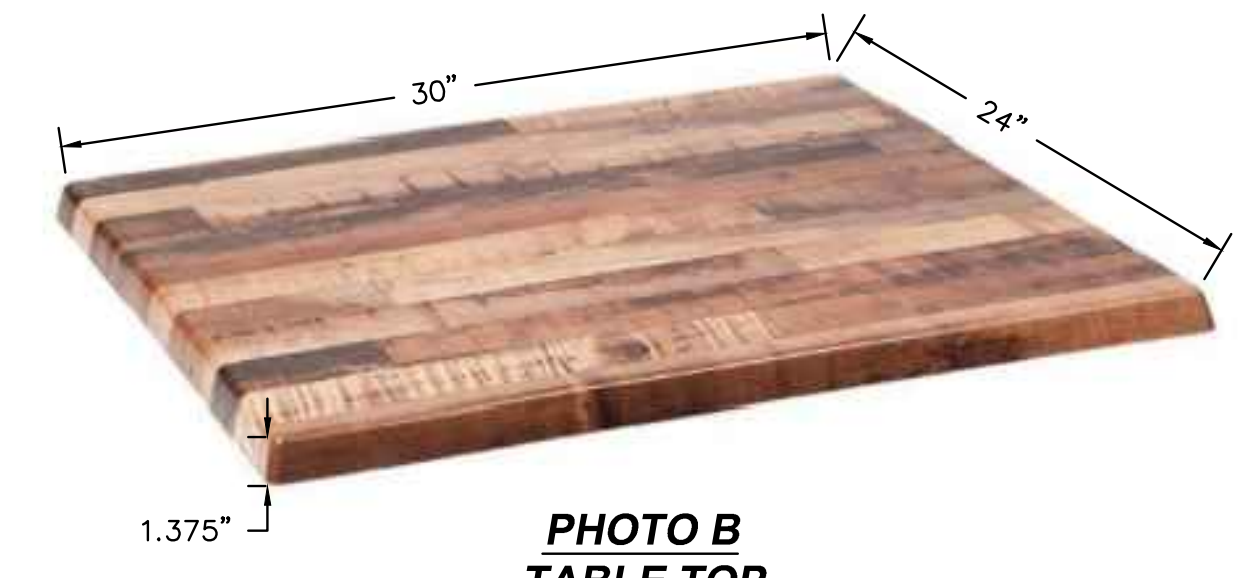
BELL IN HAND TAVERN  
45 UNION STREET

UNION STREET

**SIDEWALK CAFE PLAN**  
SCALE: 1"=10'

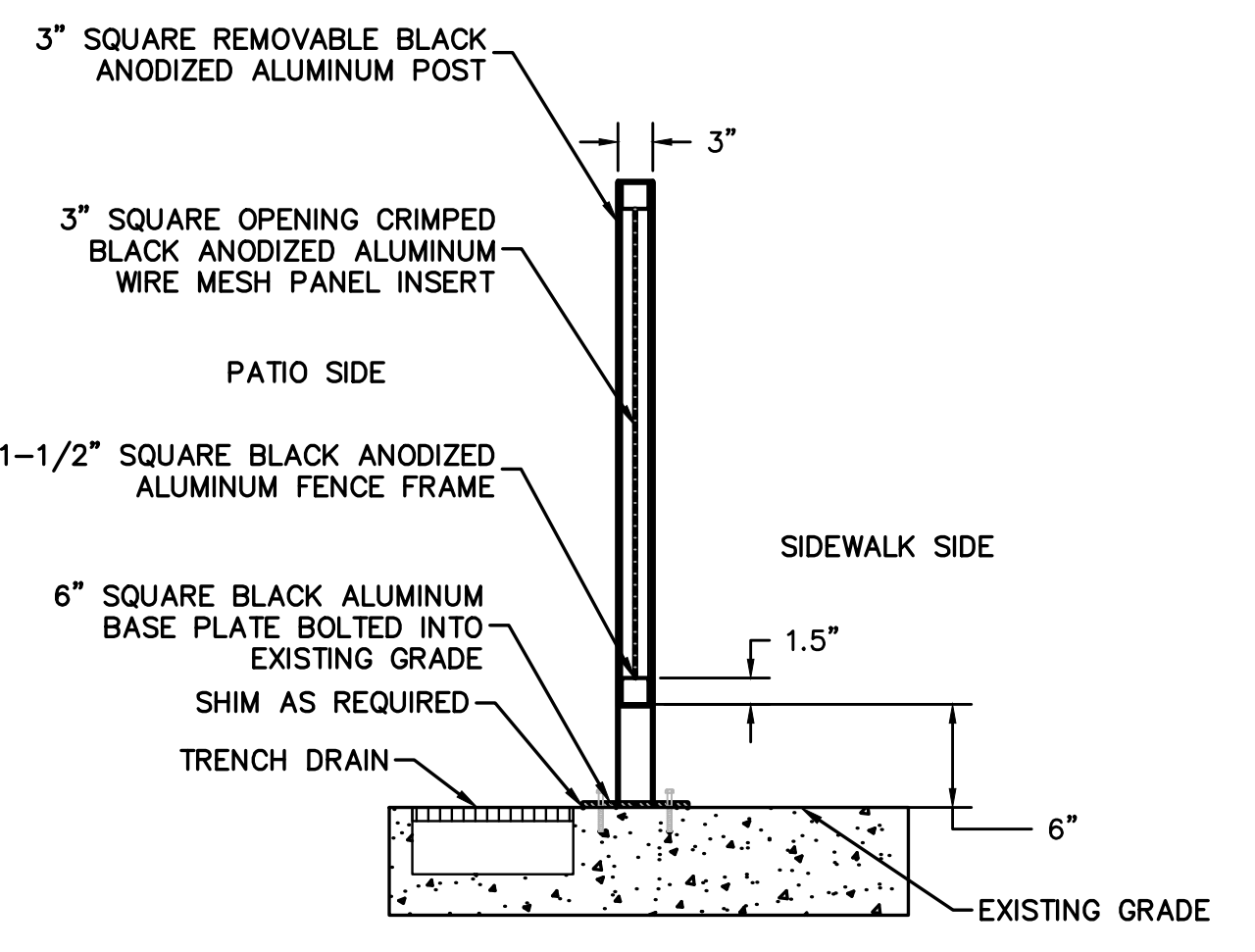


**PHOTO A**  
**ALUMINUM TABLE BASE**

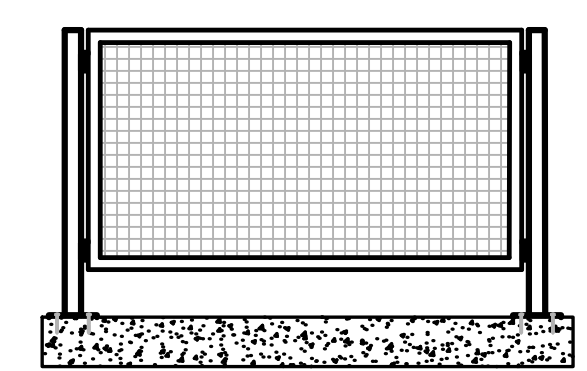


**PHOTO B**  
**TABLE TOP**

**ADA TABLE DIMENSIONS**  
30"x24"  
1.375" THICKNESS  
OVERALL HEIGHT: 31.375"



**SECTION AT REMOVABLE RAILING PANEL**  
NOT TO SCALE



**ELEVATION AT REMOVABLE RAILING PANEL**  
NOT TO SCALE



**PHOTO C**  
**ALUMINUM AND WOOD CHAIR**

CHECKED FOR GENERAL DESIGN AND CONFORMITY TO CITY STANDARDS

PUBLIC WORKS DEPARTMENT

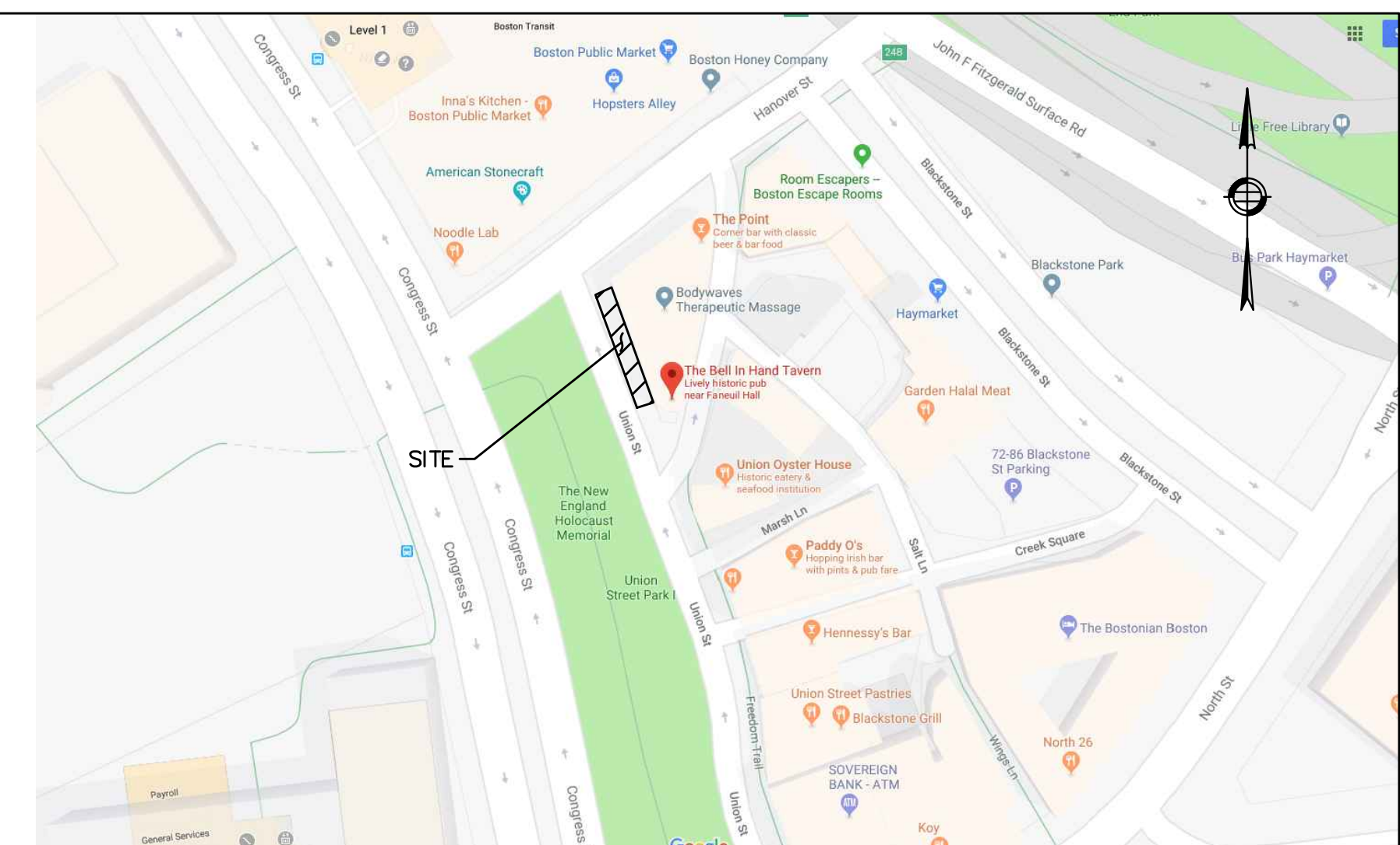
APPROVED

COMMISSIONER OF PUBLIC WORKS

PUBLIC IMPROVEMENT COMMISSION

CHIEF ENGINEER

JOHN M. SCHMID, P.E.  
MASSACHUSETTS REG. NO. 39155  
REGISTERED PROFESSIONAL ENGINEER



**LOCUS PLAN**  
NOT TO SCALE  
SOURCE: GOOGLE MAPS

FOR REGISTRY USE ONLY

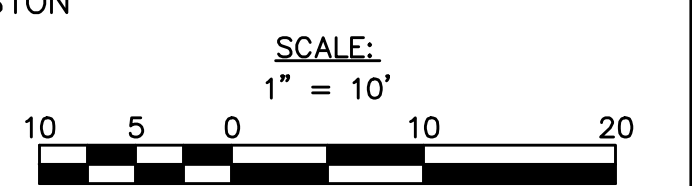
**SHEET 1 OF 1**  
PLAN SHOWING THE EXTERIOR SIDEWALK CAFE (48 SEATS)  
ON UNION STREET

CITY OF BOSTON PUBLIC WORKS DEPARTMENT  
ENGINEERING DIVISION  
SIDEWALK CAFE LICENSE PLAN

**BELL IN HAND TAVERN**  
45 UNION STREET

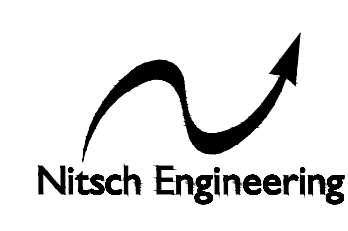
BOSTON

SCALE: HOR. 1" = 10'



DIVISION ENGINEER

JULY 2018



DESIGNED BY: PES  
DRAWN BY: PES  
CHECKED BY: JMS

PREPARED BY:  
NITSCH ENGINEERING  
2 CENTER PLAZA, SUITE 430  
BOSTON, MA 02108  
PHONE: 617-338-0063

NITSCH PROJECT NUMBER: 12948  
NITSCH FILE NAME: 12948 PIC



# Bell in Hand

# A.D. 1795

ONE WAY

FOR RENT  
1,850 - 2,500 sq. ft.  
Individual Offices  
For Rent  
617  
367-9090

Bell in Hand Tavern  
Karaoke  
Tuesday  
Nights  
9:00 pm

Bell in Hand  
Tavern  
A.D. 1795

55 Union Street





55 Union Street

ye olde  
UNION  
OYSTER  
HOUSE  
est. 1826

