



WPA Form 8A – Request for Certificate of Compliance

Massachusetts Wetlands Protection Act M.G.L. c. 131, §40

A. Project Information

Important:

When filling out forms on the computer, use only the tab key to move your cursor - do not use the return key.

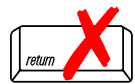

Upon completion of the work authorized in an Order of Conditions, the property owner must request a Certificate of Compliance from the issuing authority stating that the work or portion of the work has been satisfactorily completed.

1. This request is being made by:

227 Havre St LLC

Name

235 Marginal St

Mailing Address

Chelsea

City/Town

MA

State

02150

Zip Code

617-633-3533

Phone Number

2. This request is in reference to work regulated by a final Order of Conditions issued to:

227 Havre St LLC

Applicant

11/8/19

Dated

006-1610

DEP File Number

3. The project site is located at:

227 Havre St

Street Address

21147

Assessors Map/Plat Number

Boston

City/Town

0106246030

Parcel/Lot Number

4. The final Order of Conditions was recorded at the Registry of Deeds for:

Property Owner (if different)

Suffolk

County

60560

Book

168

Page

Certificate (if registered land)

5. This request is for certification that (check one):

the work regulated by the above-referenced Order of Conditions has been satisfactorily completed.

the following portions of the work regulated by the above-referenced Order of Conditions have been satisfactorily completed (use additional paper if necessary).

the above-referenced Order of Conditions has lapsed and is therefore no longer valid, and the work regulated by it was never started.



WPA Form 8A – Request for Certificate of Compliance

Massachusetts Wetlands Protection Act M.G.L. c. 131, §40

A. Project Information (cont.)

6. Did the Order of Conditions for this project, or the portion of the project subject to this request, contain an approval of any plans stamped by a registered professional engineer, architect, landscape architect, or land surveyor?

Yes

If yes, attach a written statement by such a professional certifying substantial compliance with the plans and describing what deviation, if any, exists from the plans approved in the Order.

No

B. Submittal Requirements

Requests for Certificates of Compliance should be directed to the issuing authority that issued the final Order of Conditions (OOC). If the project received an OOC from the Conservation Commission, submit this request to that Commission. If the project was issued a Superseding Order of Conditions or was the subject of an Adjudicatory Hearing Final Decision, submit this request to the appropriate DEP Regional Office (see <http://www.mass.gov/eea/agencies/massdep/about/contacts/find-the-massdep-regional-office-for-your-city-or-town.html>).



Kronos Collaborative & Kronos Companies
235 Marginal St, Chelsea, MA 02150
Email: support@kronoscos.com
P: 781-344-8372

May 6, 2021

City of Boston Environment Department
1 City Hall Square #709
Boston, MA 02201

Reference: 227 Havre Street
East Boston, MA 02128
Subject: Certificate of Compliance

To Whom It May Concern:

I, Jason Kahan P.E., certify that the above mentioned project located at 227 Havre St East Boston, MA 02128 complies with the Order of Conditions set forth by the Conservation Commission on November 8, 2018 and has been built to the plans and specifications approved by the City of Boston.

Further Questions can be answered by calling or email the contact information below
Jason Kahan P.E.

DocuSigned by:
Jason Kahan
Kronos Collaborative 1340AE8B455D405...
617-633-3533
jk@jasonkahan.com

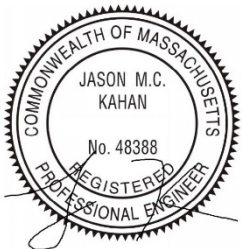

5/6/21

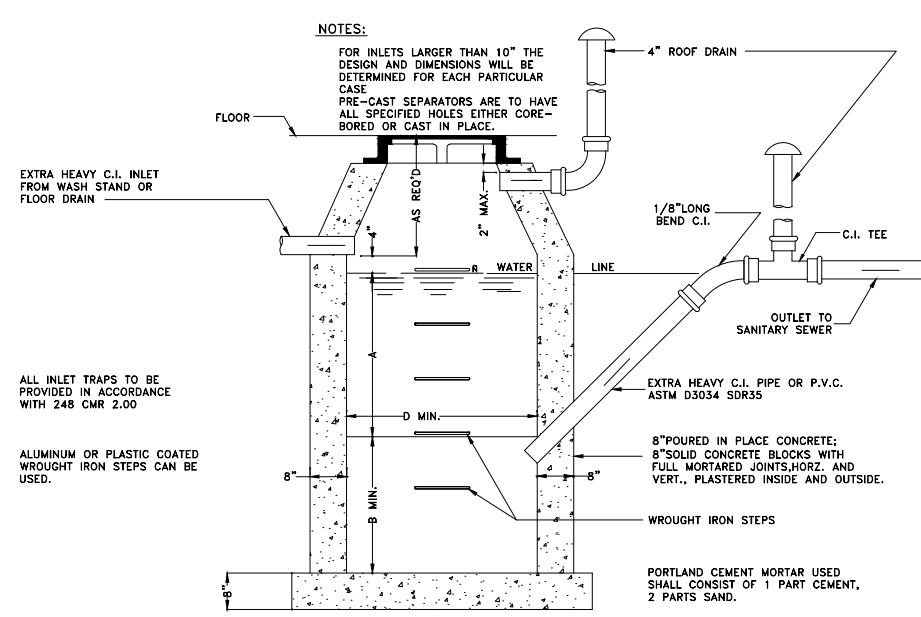
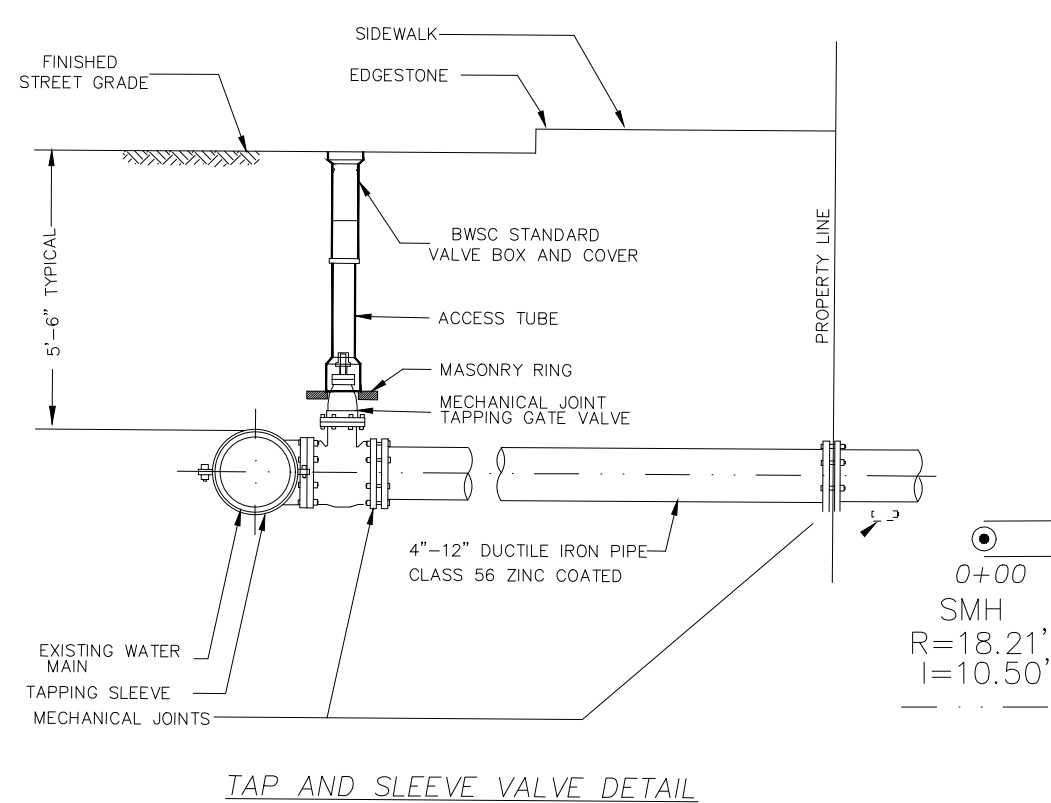
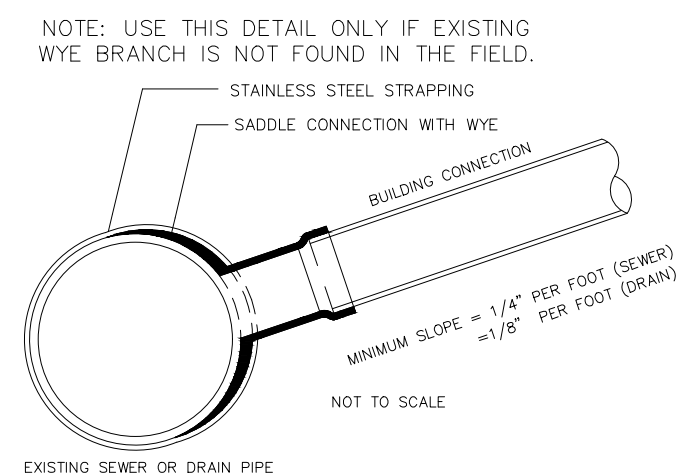
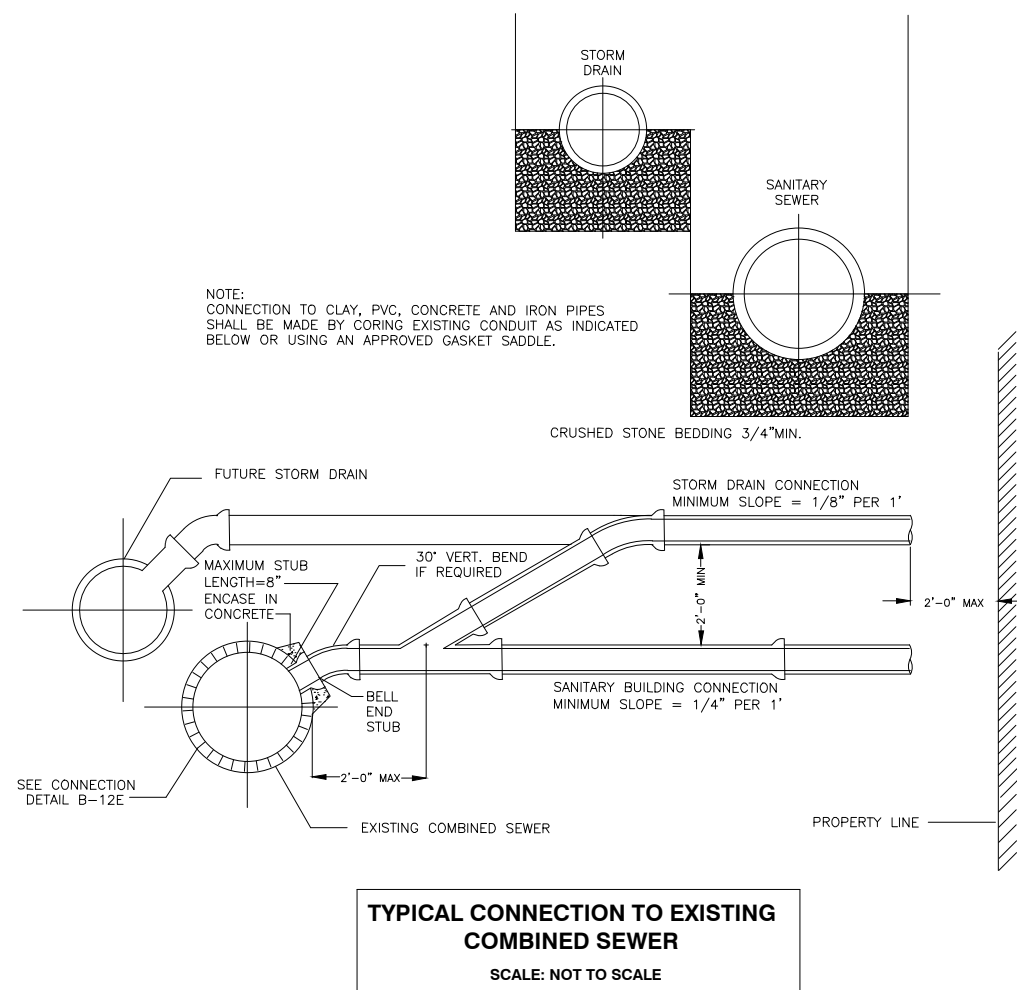

INLET	D	A	B	INLET	D	A	B
4"	3'-0"	3'-0"	3'-0"	8"	3'-0"	3'-0"	3'-0"
6"	3'-0"	3'-0"	3'-0"	12"	3'-0"	3'-0"	3'-0"
8"	3'-0"	3'-0"	3'-0"	18"	3'-0"	3'-0"	3'-0"
12"	3'-0"	3'-0"	3'-0"	24"	3'-0"	3'-0"	3'-0"
18"	3'-0"	3'-0"	3'-0"	30"	3'-0"	3'-0"	3'-0"
24"	3'-0"	3'-0"	3'-0"	36"	3'-0"	3'-0"	3'-0"
30"	3'-0"	3'-0"	3'-0"	42"	3'-0"	3'-0"	3'-0"
36"	3'-0"	3'-0"	3'-0"	48"	3'-0"	3'-0"	3'-0"
42"	3'-0"	3'-0"	3'-0"	54"	3'-0"	3'-0"	3'-0"
48"	3'-0"	3'-0"	3'-0"	60"	3'-0"	3'-0"	3'-0"

Certification is hereby made that the proposed structures shown on this plan are located within a Special Flood Hazard Area as delineated on the map of Boston (zone x) - Zone "X" is defined as Areas of 0.2% annual chance flood.

Community Panel No: 25025C081J
Effective / revised Date: MARCH 16, 2016
By the U.S. Department of Housing & Urban Development, Federal Insurance Administration.

LOT AREA
A=3,913 S.F.

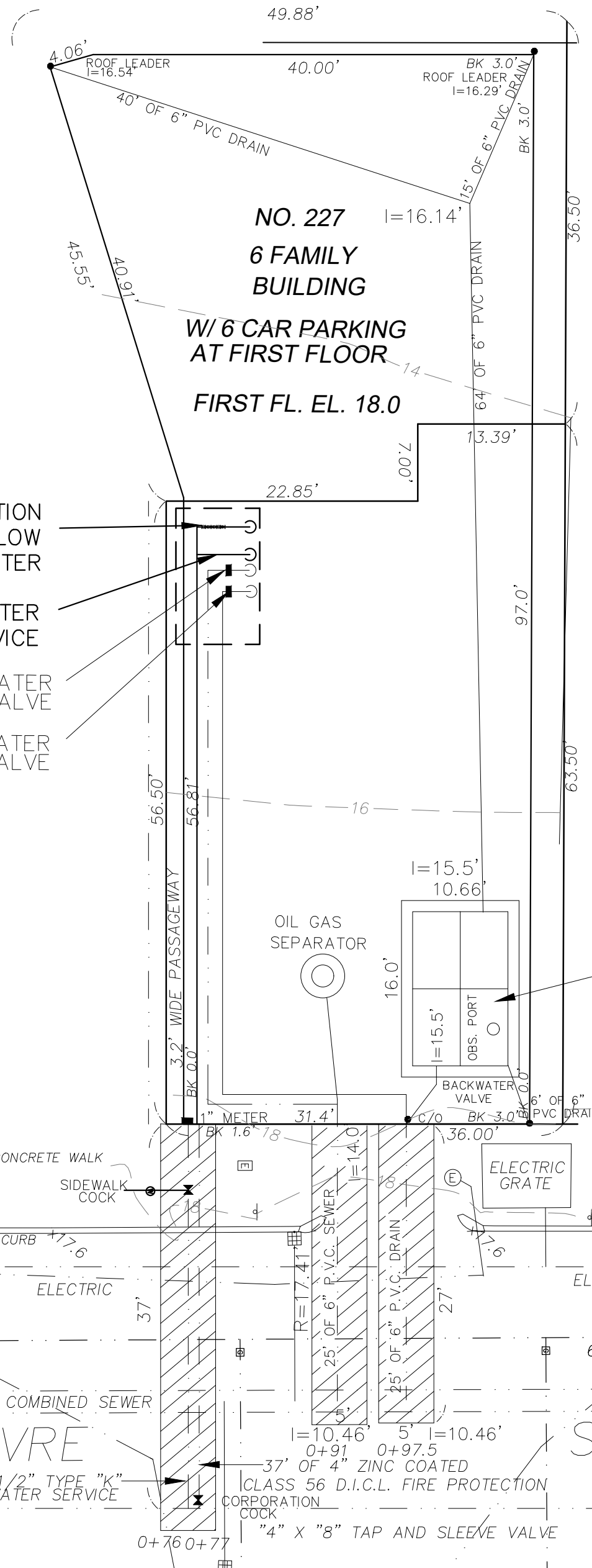

FIRE PROTECTION BACKFLOW PREVENTER
DOMESTIC WATER SERVICE
BACKWATER VALVE
BACKWATER VALVE

MAINTENANCE AGREEMENT REQUIRED
4-14.0'(L) X 4.33'(W) X 2.54'(H)
CULTEC RECHARGE MODEL 330XLHD WITH 12" OF CRUSHED STONE ALL AROUND.

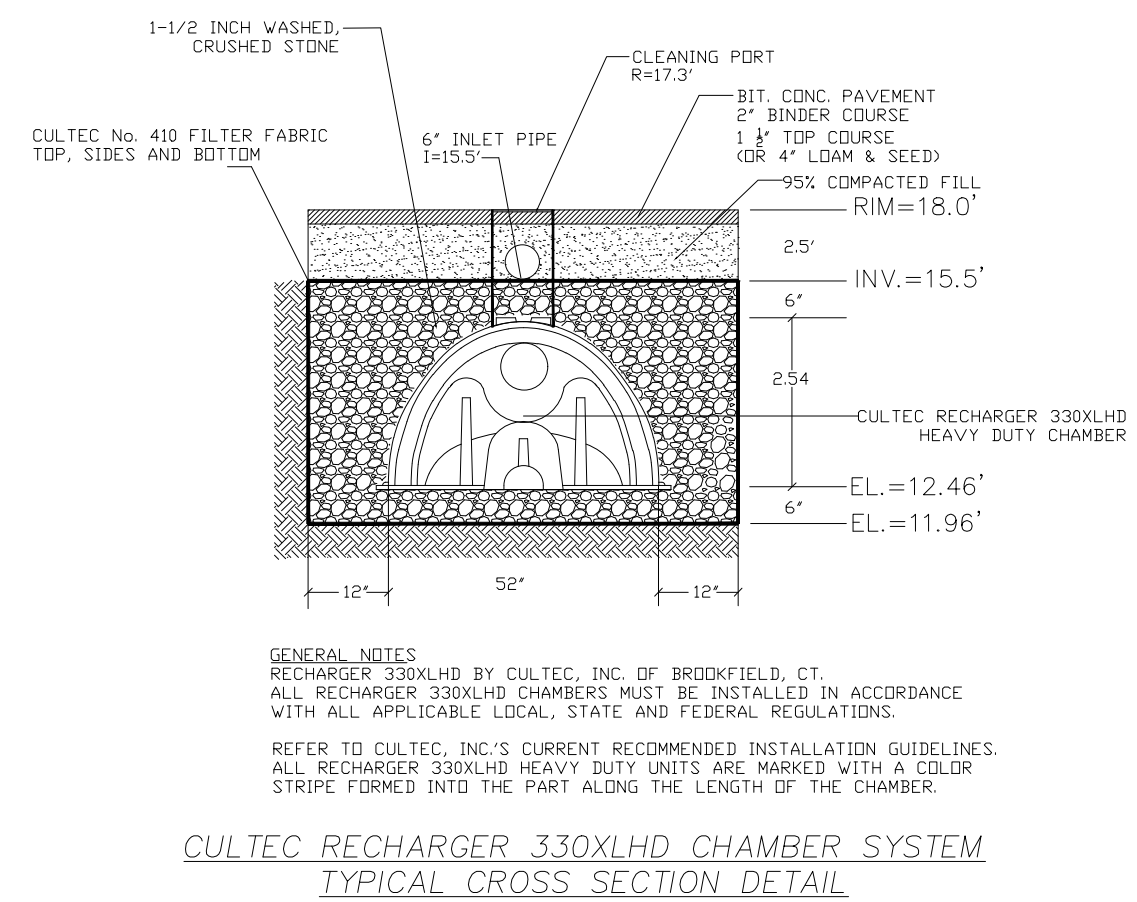
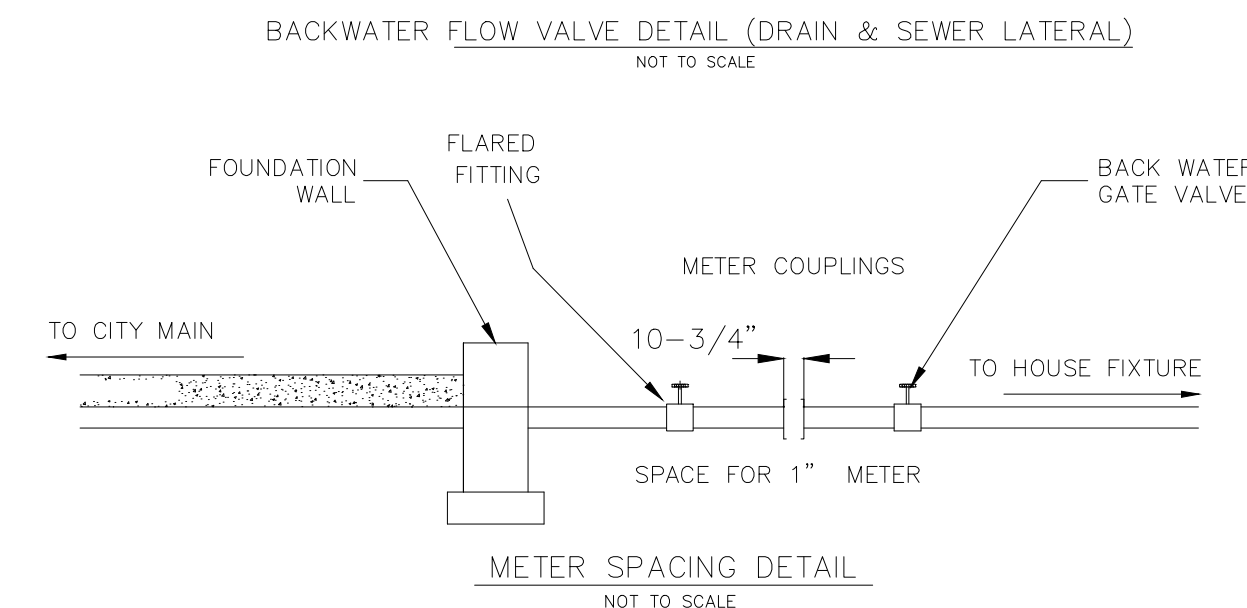
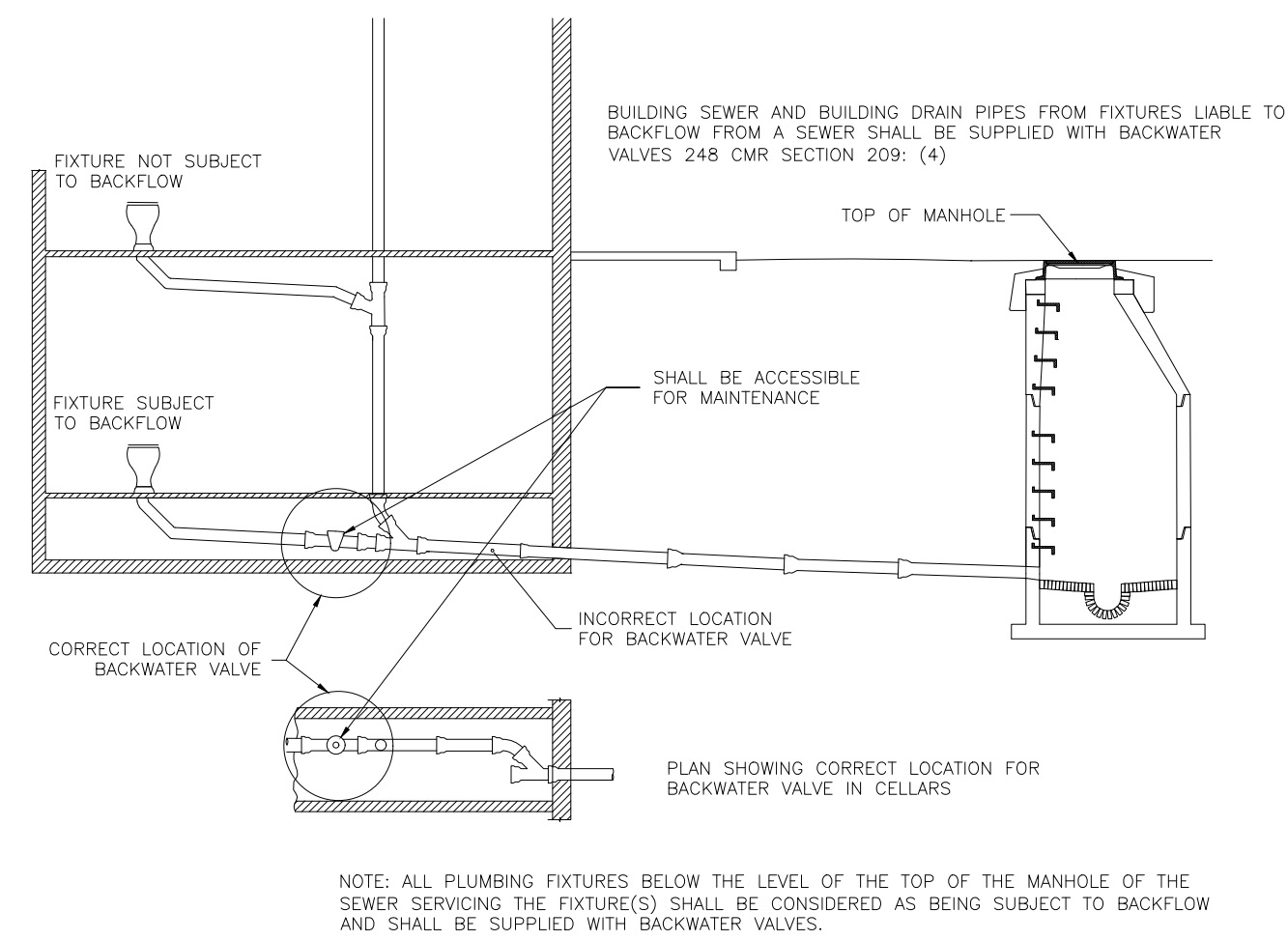

STORMWATER CALCULATIONS

TOTAL IMPERVIOUS AREA = 3,913 S.F.
TOTAL IMPERVIOUS AREA = 3,913 S.F. X 1/12 = 327 C.F.
INFILTRATION BED AREA = 10.67' X 16.0' X 3.54' = 604.2 C.F.
CULTEC PIPE CAPACITY = 7.46 C.F./FT. X 28' = 208.8 C.F.
STONE CAPACITY = 604.2 C.F. - 208.8 C.F. = 395.3 C.F. X .3 = 118.6 C.F.
TOTAL INFILTRATION CAPACITY = 208.8 + 118.6 = 327.4 C.F. > 327 C.F. D.K.
FOUR CULTEC CHAMBERS AT 14' LONG WITH 1.0' STONE ALL AROUND

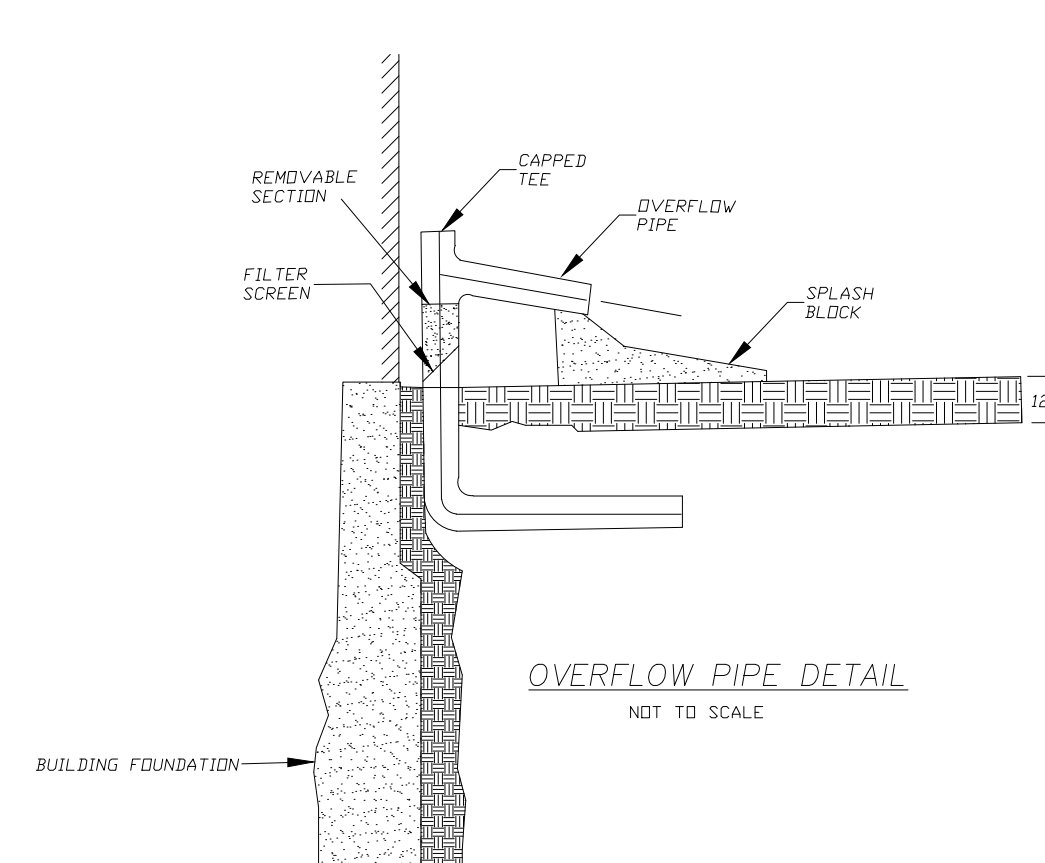
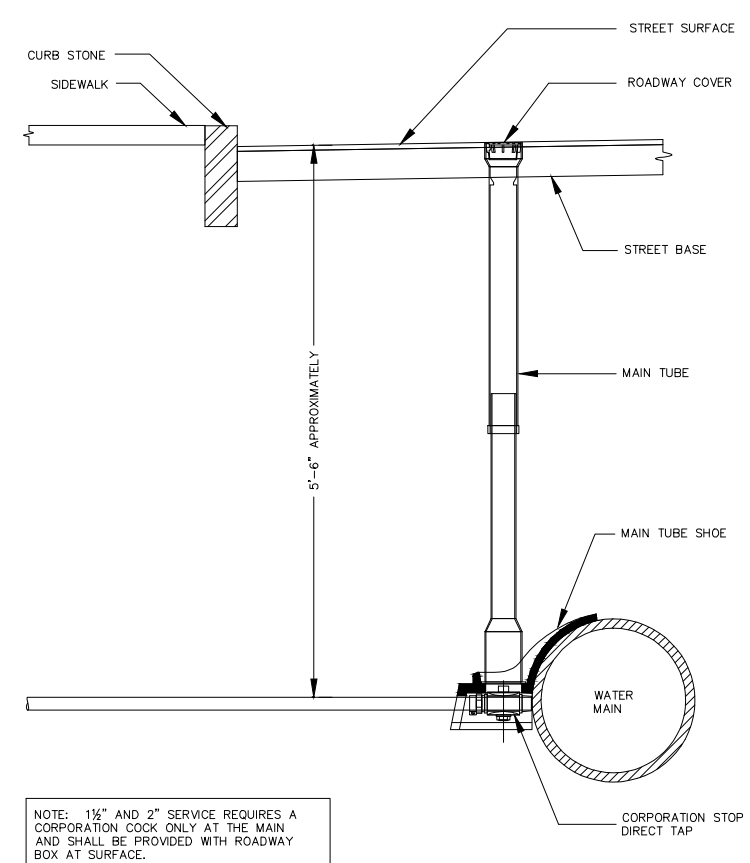
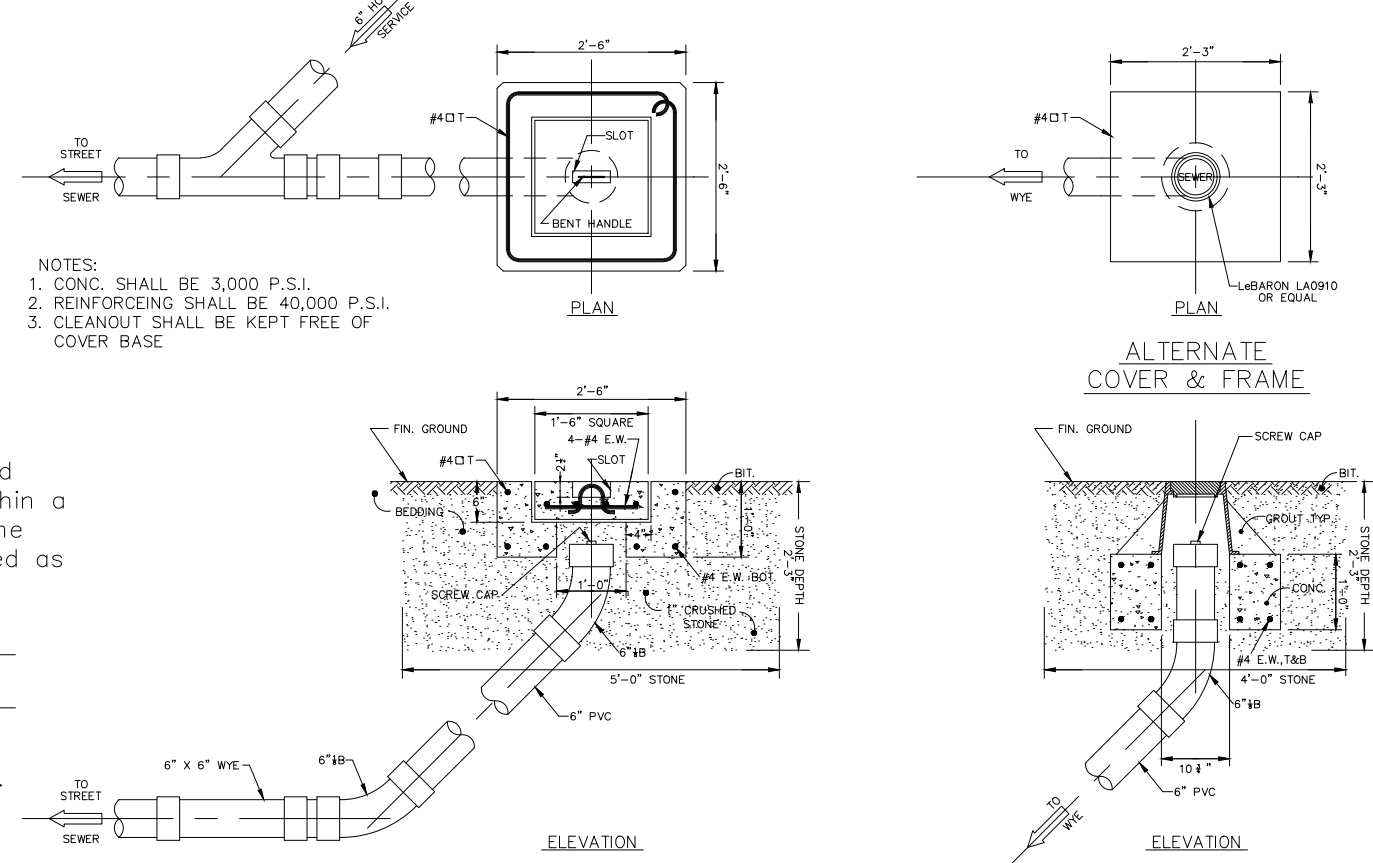

- LEGEND**
- Water Main Valve
 - Water Service/Fire/Hydrant Valve
 - Hydrant
 - LIGHT POST
 - TREE
 - Catch Basin
 - Sewer Manhole
 - EXISTING GRADE
 - UTILITY POLE
 - OVER HEAD WIRE

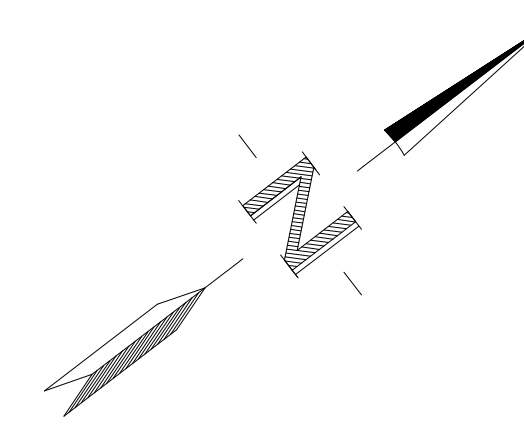

NOTES:
A PREREQUISITE FOR FILING A GENERAL SERVICE APPLICATION WITH THE BOSTON WATER AND SEWER COMMISSION FOR NEW CONSTRUCTION IS THE ROUGH CONSTRUCTION SIGN OFF DOCUMENT FROM THE CITY OF BOSTON'S INSPECTORIAL SERVICES DEPARTMENT.

ANY EXISTING WATER AND SEWER SERVICES UNCOVERED ARE TO BE ABANDONED AND SHALL BE CUT AND CAPPED AT THE MAIN IN THE STREET BY THE GENERAL CONTRACTOR.
WATER - BOSTON WATER & SEWER COMMISSION MAP
SEWER - BOSTON WATER & SEWER COMMISSION MAP

THE LOCATION OF ALL UNDERGROUND UTILITIES SHOWN ARE APPROXIMATE AND ARE BASED UPON A FIELD SURVEY AND COMPILATION OF RECORD UTILITY PLANS. N.V.S.A., INC. DOES NOT WARRANT NOR GUARANTEE THE LOCATION OF ALL OR ANY OF THE UTILITIES DEPICTED. THE CONTRACTOR SHALL VERIFY THE LOCATION OF ALL UTILITIES BY CONTACTING "DIG SAFE" AT (800) 382-4844 PRIOR TO COMMENCEMENT OF CONSTRUCTION.

PROPOSED BUILDING TO CONTAIN SIX UNITS EACH WITH 2 BEDROOMS FOR A TOTAL OF 12 BEDROOMS @ 110 G.P.D. = 1,320 GPD TOTAL SEWER FLOW

AS-BUILT PLAN
FOR
227R HAVRE STREET
IN
EAST BOSTON
PREPARED FOR:
JASON KAHAN

PREPARED BY:
KRONOS COLLABORATIVE

235 MARGINAL ST.,
CHELSEA, MA 02150

AUGUST, 28, 2011
SCALE 1" = 10'

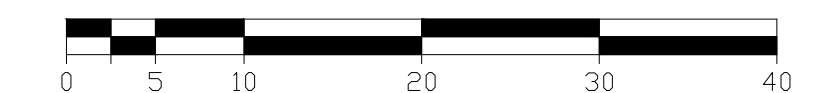

PID	OWNER	ADDRESSEE	MLG_ADDRESS	MLG_CITYSTA	MLG_ZIP	LOC_ADDRESS	LOC_CITY	LOC_ZIP
106205000	PIRRELLO MARIE LT	C/O MARIE PIRRELLO	192 PARIS ST	EAST BOSTON	2128	192 PARIS ST	EAST BOST	2128
106204000	AMAYA MARIA E	C/O MARIA AMAYA	194 PARIS ST	EAST BOSTON	2128	194 PARIS ST	EAST BOST	2128
106190000	BRUNO PAUL TS	PAUL S BRUNO TS	107 ORLEANS ST	E BOSTON MA	2128	197 MARION S	EAST BOST	2128
106203000	ALIAGA RAUL	C/O RAUL ALIAGA	2 CARLSON CI	WEST ROXBUR	2132	202 PARIS ST	EAST BOST	2128
106202000	AMORE TONE B	C/O TONE B AMORE	206 PARIS ST	EAST BOSTON	2128	206 PARIS ST	EAST BOST	2128
106201000	ESCOBAR MAURICIO		210 PARIS ST	EAST BOSTON	2128	210 PARIS ST	EAST BOST	2128
106240000	215 HAVRE STREET TR	C/O PASQUALE MELE	215 HAVRE ST	EAST BOSTON	2128	215 HAVRE ST	EAST BOST	2128
106200000	VALENTIN ISMAEL	C/O ERIC MARBERBLATT TR	216 PARIS ST	EAST BOSTON	2128	216 PARIS ST	EAST BOST	2128
106241000	MORAN CARLOS	C/O CARLOS MORAN	217 HAVRE ST	EAST BOSTON	2128	217 HAVRE ST	EAST BOST	2128
106125001	218-220 HAVRE STREI	C/O 218-220 HAVRE STREE	1281 WALNUT ST #1	NEWTON MA	2461	218 HAVRE ST	EAST BOST	2128
106199000	BRUNO PAUL S TS	C/O PAUL S BRUNO	218 PARIS ST	EAST BOSTON	2128	218 PARIS ST	EAST BOST	2128
106198000	GIRALDO ALCIDES L	C/O ALCIDES L GIRALDO	220 PARIS ST	EAST BOSTON	2128	220 PARIS ST	EAST BOST	2128
106242000	PIAZZA SANTO TS	C/O FRANCESCA PIAZZA	1 AMANDA DR	DANVERS MA	1923	221 HAVRE ST	EAST BOST	2128
106197000	DILORENZO ANTHON'		222 PARIS	EAST BOSTON	2128	222 PARIS ST	EAST BOST	2128
106243000	PIAZZA SEBASTIANO	C/O SANTO PIAZZA	1 AMANDA DR	DANVERS MA	1923	223 HAVRE ST	EAST BOST	2128
106196000	LOPEZ MIGUEL A	C/O MIGUEL A LOPEZ	10 PRINCETON ST	EAST BOSTON	2128	224 PARIS ST	EAST BOST	2128
106244000	227 HAVRE STREET LL	C/O 227 HAVRE STREET LLC	17 MILL RUN RD	BOXFORD MA	1921	225 HAVRE ST	EAST BOST	2128
106124000	RUIZ LUIS	C/O LUIS RUIZ	226 HAVRE ST	EAST BOSTON	2128	226 HAVRE ST	EAST BOST	2128
106246030	227 HAVRE STREET LL	C/O 227 HAVRE STREET LLC	17 MILL RUN ROAD	BOXFORD MA	1921	227 HAVRE ST	EAST BOST	2128
106123000	SMITH MICHAEL RYAI	C/O LEANDRO CONTRERAS	228 HAVRE ST	EAST BOSTON	2128	228 HAVRE ST	EAST BOST	2128
106245000	BRUNO PAUL	C/O PAUL BRUNO	218 PARIS ST	BOSTON MA	2128	229 HAVRE ST	EAST BOST	2128
106122000	VELASQUEZ JAIME	C/O JAIME VELASQUEZ	230 HAVRE ST	EAST BOSTON	2128	230 HAVRE ST	EAST BOST	2128
106121000	COREAS PEDRO A	ANA COREAS	37 FALCON ST	E BOSTON MA	2128	232 HAVRE ST	EAST BOST	2128
106120000	MCNUTT JASON	C/O JASON MCNUTT	236 HAVRE ST	EAST BOSTON	2128	236 HAVRE ST	EAST BOST	2128
106246020	BRUNO PAUL	C/O PAUL BRUNO	218 PARIS STREET	BOSTON MA	2128	237 HAVRE ST	EAST BOST	2128
106119000	FARD NASSER S	C/O NASSER S FARD	5 EVELYN RD	WABAN MA	2468	238 HAVRE ST	EAST BOST	2128
106247000	BRUNO PAUL S TS	C/O PAUL S BRUNO TS	218 PARIS STREET	BOSTON MA	2128	239 HAVRE ST	EAST BOST	2128
106118000	SMOOT DONALD J TS	C/O STEVEN F SMOOT PR	PO BOX 12-245	BOSTON MA	2112	240 HAVRE ST	EAST BOST	2128
106248000	BRUNO PAUL S TS	C/O PAUL S BRUNO	218 PARIS ST	BOSTON MA	2128	241 HAVRE ST	EAST BOST	2128
106244010	PIAZZA SANTO	C/O SANTO PIAZZA	1 AMANDA DR	DANVERS MA	1923	HAVRE ST	EAST BOST	2128

106246040	PIAZZA SANTO	C/O SANTO PIAZZA	1 AMANDA DR	DANVERS MA	1923	HAVRE ST	EAST BOST	2128
106245001	FRIZZI CONO TRSTS		6 WEST WOODCRES	MELROSE MA	2176	HAVRE ST	EAST BOST	2128
106246010	FRIZZI MARIE TS		6 WOODCREST DR	MELROSE MA	2176	HAVRE ST	EAST BOST	2128
106204001	AMAYA MARIA E	C/O MARIA E AMAYA	194 PARIS ST	EAST BOSTON	2128	PARIS ST	EAST BOST	2128



BABEL NOTICE

English:

IMPORTANT! This document or application contains **important information** about your rights, responsibilities and/or benefits. It is crucial that you understand the information in this document and/or application, and we will provide the information in your preferred language at no cost to you. If you need them, please contact us at cc@boston.gov or 617-635-3850.

Spanish:

¡IMPORTANTE! Este documento o solicitud contiene **información importante** sobre sus derechos, responsabilidades y/o beneficios. Es fundamental que usted entienda la información contenida en este documento y/o solicitud, y le proporcionaremos la información en su idioma preferido sin costo alguno para usted. Si los necesita, póngase en contacto con nosotros en el correo electrónico cc@boston.gov o llamando al 617-635-3850.

Haitian Creole:

AVI ENPÒTAN! Dokiman oubyen aplikasyon sa genyen **enfòmasyon ki enpòtan** konsènan dwa, responsablite, ak/oswa benefis ou yo. Li enpòtan ke ou konprann enfòmasyon ki nan dokiman ak/oubyen aplikasyon sa, e n ap bay enfòmasyon an nan lang ou prefere a, san ou pa peye anyen. Si w bezwen yo, tanpri kontakte nou nan cc@boston.gov oswa 617-635-3850.

Traditional Chinese:

非常重要！這份文件或是申請表格包含關於您的權利，責任，和／或福利的重要信息。請您務必完全理解這份文件或申請表格的全部信息，這對我們來說十分重要。我們會免費給您提供翻譯服務。如果您有需要請聯系我們的郵箱 cc@boston.gov 電話# 617-635-3850..

Vietnamese:

QUAN TRỌNG! Tài liệu hoặc đơn yêu cầu này chứa **thông tin quan trọng** về các quyền, trách nhiệm và/hoặc lợi ích của bạn. Việc bạn hiểu rõ thông tin trong tài liệu và/hoặc đơn yêu cầu này rất quan trọng, và chúng tôi sẽ cung cấp thông tin bằng ngôn ngữ bạn muốn mà không tính phí. Nếu quý vị cần những dịch vụ này, vui lòng liên lạc với chúng tôi theo địa chỉ cc@boston.gov hoặc số điện thoại 617-635-3850.

Simplified Chinese:

非常重要！这份文件或是申请表格包含关于您的权利，责任，和／或福利的重要信息。请您务必完全理解这份文件或申请表格的全部信息，这对我们来说十分重要。我们会免费给您提供翻译服务。如果您有需要请联联系我们的邮箱 cc@boston.gov 电话# 617-635-3850.

Cape Verdean Creole:

INPURTANTI! Es dukumentu ó aplikason ten **informason inpur tanti** sobri bu direitus, rasponsabilidadi i/ó benefisius. Ê krusial ki bu intendi informason na es dukumentu i/ó aplikason ó nu ta da informason na língua di bu preferênsia sen ninhun kustu pa bó. Si bu prisiza del, kontata-nu na cc@boston.gov ó 617-635-3850.

Arabic:

مهم! يحتوي هذا المستند أو التطبيق على معلومات مهمة حول حقوقك ومسؤولياتك أو فوائدك. من الأهمية أن تفهم المعلومات الواردة في هذا المستند أو التطبيق. سوف نقدم المعلومات بلغتك المفضلة دون أي تكلفة عليك. إذا كنت في حاجة إليها، يرجى الاتصال بنا على cc@boston.gov أو 617-635-3850.

Russian:

ВАЖНО! В этом документе или заявлении содержится **важная информация** о ваших правах, обязанностях и/или льготах. Для нас очень важно, чтобы вы понимали приведенную в этом документе и/или заявлении информацию, и мы готовы бесплатно предоставить вам информацию на предпочитаемом вами языке. Если Вам они нужны, просьба связаться с нами по адресу электронной почты cc@boston.gov, либо по телефону 617-635-3850.

Portuguese:

IMPORTANTE! Este documento ou aplicativo contém **Informações importantes** sobre os seus direitos, responsabilidades e/ou benefícios. É importante que você compreenda as informações contidas neste documento e/ou aplicativo, e nós iremos fornecer as informações em seu idioma de preferência sem nenhum custo para você. Se precisar deles, fale conosco: cc@boston.gov ou 617-635-3850.

French:

IMPORTANT ! Ce document ou cette demande contient des **informations importantes** concernant vos droits, responsabilités et/ou avantages. Il est essentiel que vous compreniez les informations contenues dans ce document et/ou cette demande, que nous pouvons vous communiquer gratuitement dans la langue de votre choix. Si vous en avez besoin, veuillez nous contacter à cc@boston.gov ou au 617-635-3850.





**NOTIFICATION TO ABUTTERS
BOSTON CONSERVATION COMMISSION**

In accordance with the Massachusetts Wetlands Protection Act, Massachusetts General Laws Chapter 131, Section 40, and the Boston Wetlands Ordinance, you are hereby notified as an abutter to a project filed with the Boston Conservation Commission.

A. **227 Havre Street LLC** has filed a Notice of Intent with the Boston Conservation Commission seeking permission to alter an Area Subject to Protection under the Wetlands Protection Act (General Laws Chapter 131, section 40) and Boston Wetlands Ordinance.

B. The address of the lot where the activity is proposed is **227 Havre Street East Boston, MA 02128**

C. The project involves **6 unit residential new construction with 6 car parking on first floor.**

D. Copies of the Notice of Intent may be obtained by contacting the Boston Conservation Commission at CC@boston.gov.

E. Copies of the Notice of Intent may be obtained from **Jason Kahan at 617-633-3533 or jk@jasonkahan.com** between the hours of **9am-5pm, Monday-Friday.**

F. In accordance with the Commonwealth of Massachusetts Executive Order Suspending Certain Provisions of the Open Meeting Law, the public hearing will take place **virtually** at <https://zoom.us/j/6864582044>. If you are unable to access the internet, you can call 1-929-205-6099, enter Meeting ID 686 458 2044 # and use # as your participant ID.

G. Information regarding the date and time of the public hearing may be obtained from the **Boston Conservation Commission** by emailing CC@boston.gov or calling **(617) 635-3850** between the hours of **9 AM to 5 PM, Monday through Friday.**

NOTE: Notice of the public hearing, including its date, time, and place, will be published at least five (5) days in advance in the **Boston Herald.**

NOTE: Notice of the public hearing, including its date, time, and place, will be posted on www.boston.gov/public-notices and in Boston City Hall not less than forty-eight (48) hours in advance.

NOTE: If you would like to provide comments, you may attend the public hearing or send written comments to CC@boston.gov or Boston City Hall, Environment Department, Room 709, 1 City Hall Square, Boston, MA 02201

NOTE: You also may contact the Boston Conservation Commission or the Department of Environmental Protection Northeast Regional Office for more information about this application or the Wetlands Protection Act. To contact DEP, call: the Northeast Region: (978) 694-3200.



City of Boston
Environment



City of Boston
Mayor Martin J. Walsh

**AFFIDAVIT OF SERVICE
FOR ABUTTER NOTIFICATION**

**Under the Massachusetts Wetlands Protection Act
and Boston Wetlands Ordinance**

I, Jason Kahan, hereby certify under pains and penalties of perjury that that at least one week prior to the public hearing, I gave notice to abutters in compliance with the second paragraph of Massachusetts General Laws Chapter 131, section 40, and the DEP Guide to Abutter Notification dated April 8, 1994, in connection with the following matter:

A Request for a Certificate of Compliance was filed under the Massachusetts Wetlands Protection Act and/or the Boston Wetlands Ordinance by 227 Havre Street LLC for a 6 unit residential building with 6 car parking on the first floor located at 227 Havre Street East Boston, MA 02128.

The Abutter Notification For, the list of abutters to whom it was given, and their addresses are attached to this Affidavit of Service.

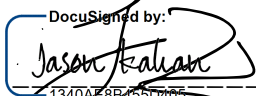
DocuSigned by:

1340AE8B455D465...
Name

5/11/2021

Date



**NOTIFICACIÓN PARA PROPIETARIOS Y/O VECINOS COLINDANTES
COMISIÓN DE CONSERVACIÓN DE BOSTON**

De conformidad con la Ley de protección de los humedales de Massachusetts, el Capítulo 131, Sección 40 de las Leyes Generales de Massachusetts y la Ordenanza sobre los humedales de Boston, por la presente queda usted notificado como propietario o vecino colindante de un proyecto presentado ante la Comisión de Conservación de Boston.

A. **227 Havre Street LLC** ha presentado una solicitud a la Comisión de Conservación de Boston pidiendo permiso para modificar una zona sujeta a protección en virtud de la Ley de protección de los humedales (Leyes generales, capítulo 131, sección 40) y la Ordenanza sobre los humedales de Boston.

B. La dirección del lote donde se propone la actividad es **227 Havre Street East Boston, MA 02128**.

C. El proyecto consiste en **Residencial de 6 unidades de nueva construcción con estacionamiento para 6 autos en primer piso..**

D. Se pueden obtener copias del Aviso de Intención comunicándose con la Comisión de Conservación de Boston en CC@boston.gov.

E. Las copias de la notificación de intención pueden obtenerse en **Jason Kahan, 617-633-3533, jk@jasonkahan.com entre las 9am-5pm, Lunes-Viernes.**

F. De acuerdo con el Decreto Ejecutivo de la Mancomunidad de Massachusetts que suspende ciertas disposiciones de la Ley de reuniones abiertas, la audiencia pública se llevará a cabo virtualmente en <https://zoom.us/j/6864582044>. Si no puede acceder a Internet, puede llamar al 1-929-205-6099, ingresar ID de reunión 686 458 2044 # y usar # como su ID de participante.

G. La información relativa a la fecha y hora de la audiencia pública puede solicitarse a la **Comisión de Conservación de Boston** por correo electrónico a CC@boston.gov o llamando al **(617) 635-4416** entre las **9 AM y las 5 PM, de lunes a viernes.**

NOTA: La notificación de la audiencia pública, incluida su fecha, hora y lugar, se publicará en el **Boston Herald** con al menos cinco (5) días de antelación.

NOTA: La notificación de la audiencia pública, incluida su fecha, hora y lugar, se publicará en www.boston.gov/public-notices y en el Ayuntamiento de Boston con no menos de cuarenta y ocho (48) horas de antelación. Si desea formular comentarios, puede asistir a la audiencia pública o enviarlos por escrito a CC@boston.gov o al Ayuntamiento de Boston, Departamento de Medio Ambiente, Sala 709, 1 City Hall Square, Boston, MA 02201.

NOTA: También puede comunicarse con la Comisión de Conservación de Boston o con la Oficina Regional del Noreste del Departamento de Protección Ambiental para obtener más información sobre esta solicitud o la Ley de Protección de Humedales. Para comunicarse con el DEP, llame a la Región Noreste: (978) 694-3200.



City of Boston
Environment



City of Boston
Mayor Martin J. Walsh

NOTA: si tiene previsto asistir a la audiencia pública y necesita servicios de interpretación, sírvase informar al personal en CC@boston.gov antes de las 12 PM del día anterior a la audiencia.

May 6, 2021

City of Boston Environment Department

1 City Hall Square #709

Boston, MA 02201

Subject: Certification of Translation

To Whom It May Concern:

I, Nestor Limas, certify that the translation of the attached letter from English to Spanish is complete and accurate. I have spoken fluent English and Spanish for 40 years. Feel free to reach out with any questions or concerns with this translation.

Thank you,

Nestor Limas 5FCE66558B004F3...