

4 CALLOUT A - UNIT 10
1 1/2" = 1'-0"

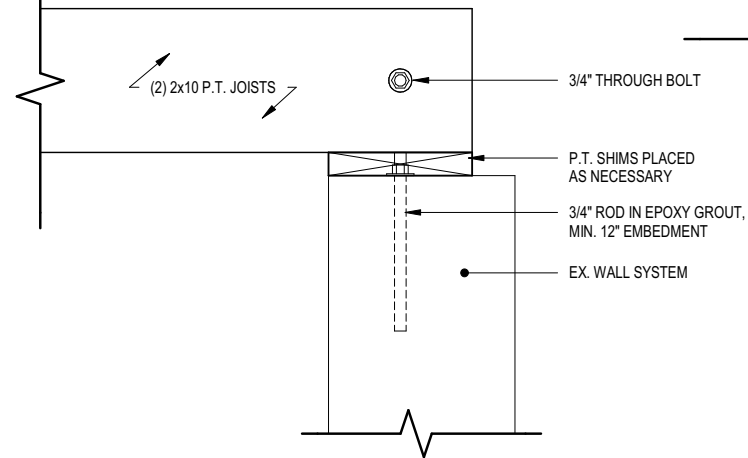

3 CALLOUT B - UNIT 10
1 1/2" = 1'-0"

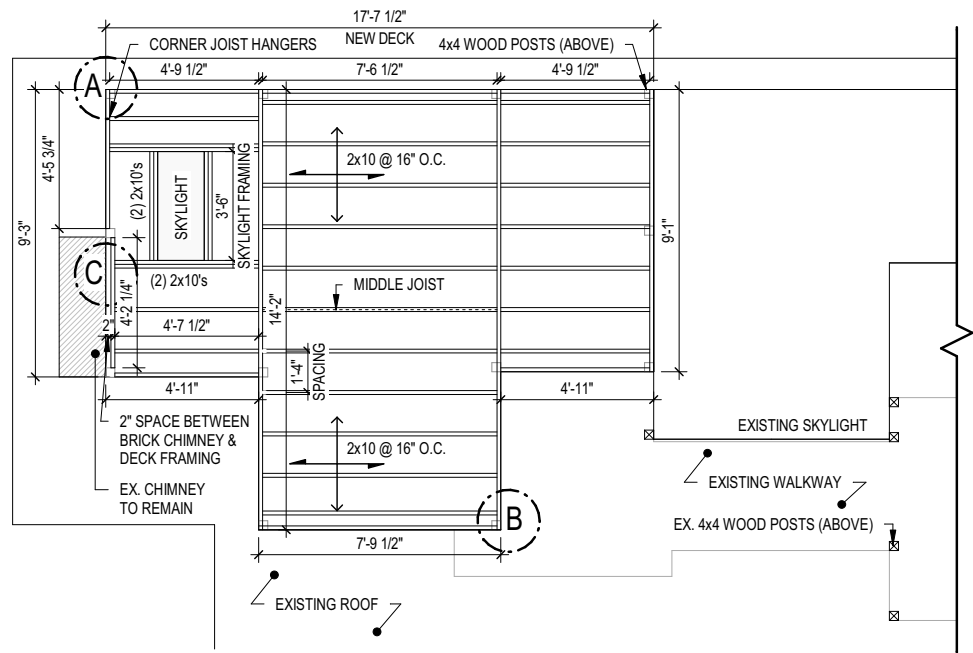

2 CALLOUT C - UNIT 10
1 1/2" = 1'-0"

1 ROOF DECK UNIT 10 - FRAMING PLAN
1/4" = 1'-0"

NOTES:
1. ALL WOOD IS TO BE PRESSURE TREATED SPF#2 OR BETTER
2. GENERAL CONTRACTOR IS TO VERIFY ALL FIELD CONDITIONS AND DIMENSIONS

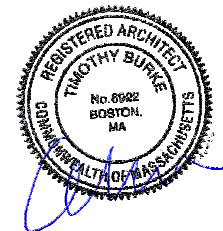

Timothy Burke
ARCHITECTURE
142 BERKELEY STREET, BOSTON MASSACHUSETTS 02116
P: 617.266.1332 | W: timothyburke.net | F: 617.266.1116

Date: 08/16/2019 Author
Drawn By:
DECK UNIT 10 FRAMING & DETAILS
Refer To:

7 PRIMUS AVENUE, UNIT 10, BEACON HILL, BOSTON, MASSACHUSETTS 02108

A10.2

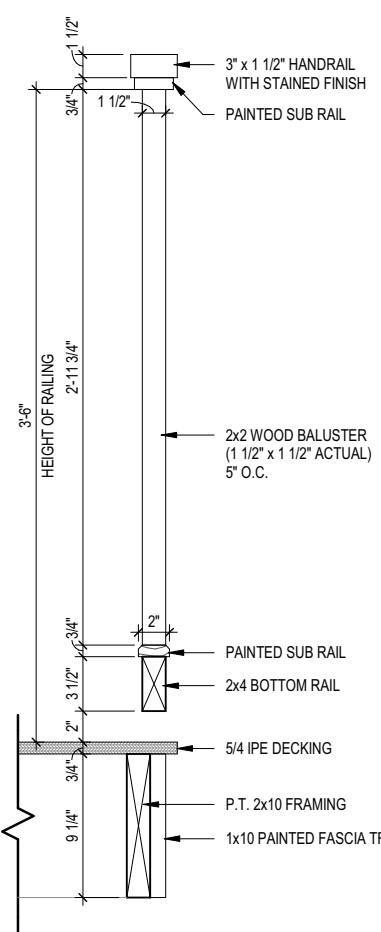

4 TYP. RAILING - DETAIL (UNIT 10)
1 1/2" = 1'-0"

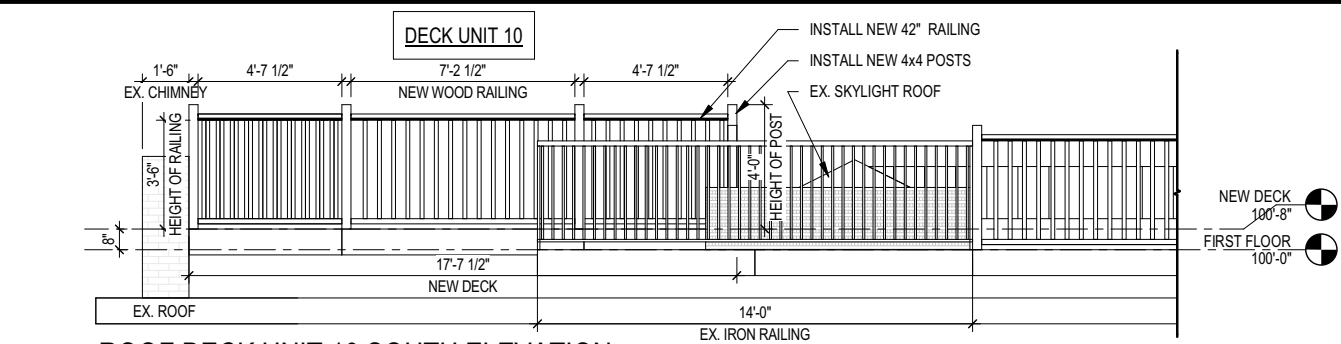

3 ROOF DECK UNIT 10 SOUTH ELEVATION - PROPOSED
1/4" = 1'-0"

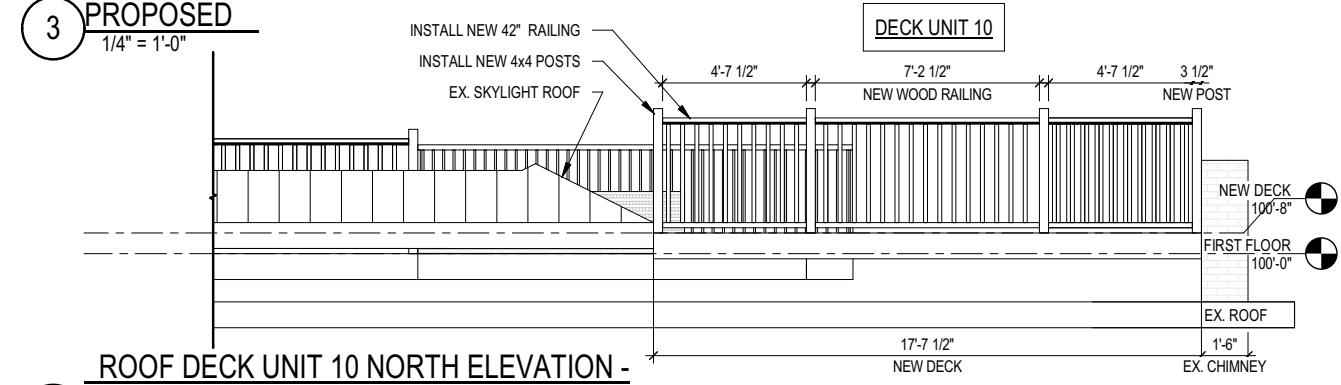

2 ROOF DECK UNIT 10 NORTH ELEVATION - PROPOSED
1/4" = 1'-0"

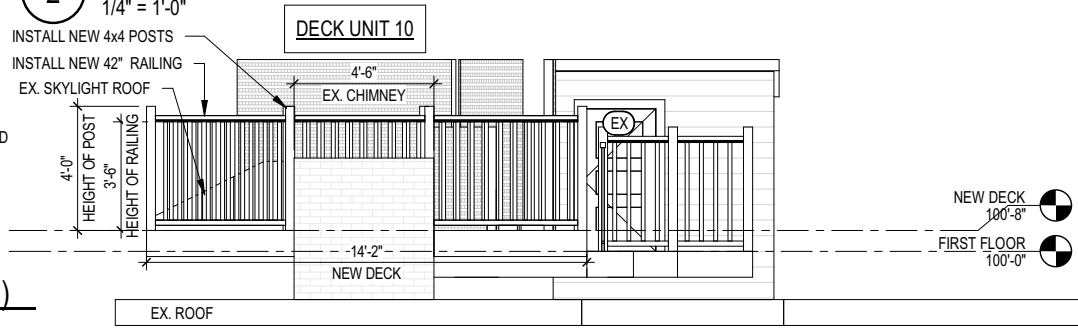

1 ROOF DECK UNIT 10 WEST ELEVATION - PROPOSED
1/4" = 1'-0"

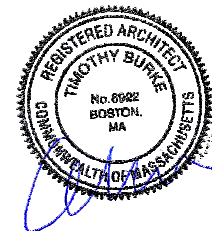

Timothy Burke
ARCHITECTURE

142 BERKELEY STREET, BOSTON MASSACHUSETTS 02116
P: 617.266.1332 | W: timothyburke.net | F: 617.266.1116

Date: 08/16/2019 Author
Drawn By:
DECK UNIT 10 ELEVATIONS

7 PRIMUS AVENUE, UNIT 10, BEACON HILL, BOSTON, MASSACHUSETTS 02108

A10.3