

18 SHUTTER HEAD  
3"=1'-0"

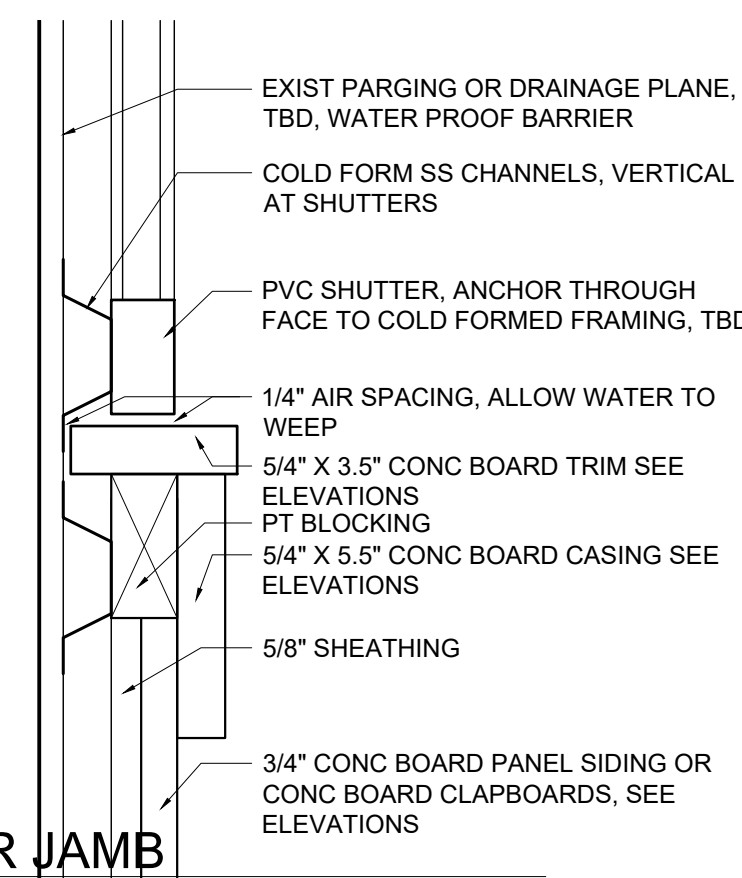

17 SHUTTER JAMB  
3"=1'-0"

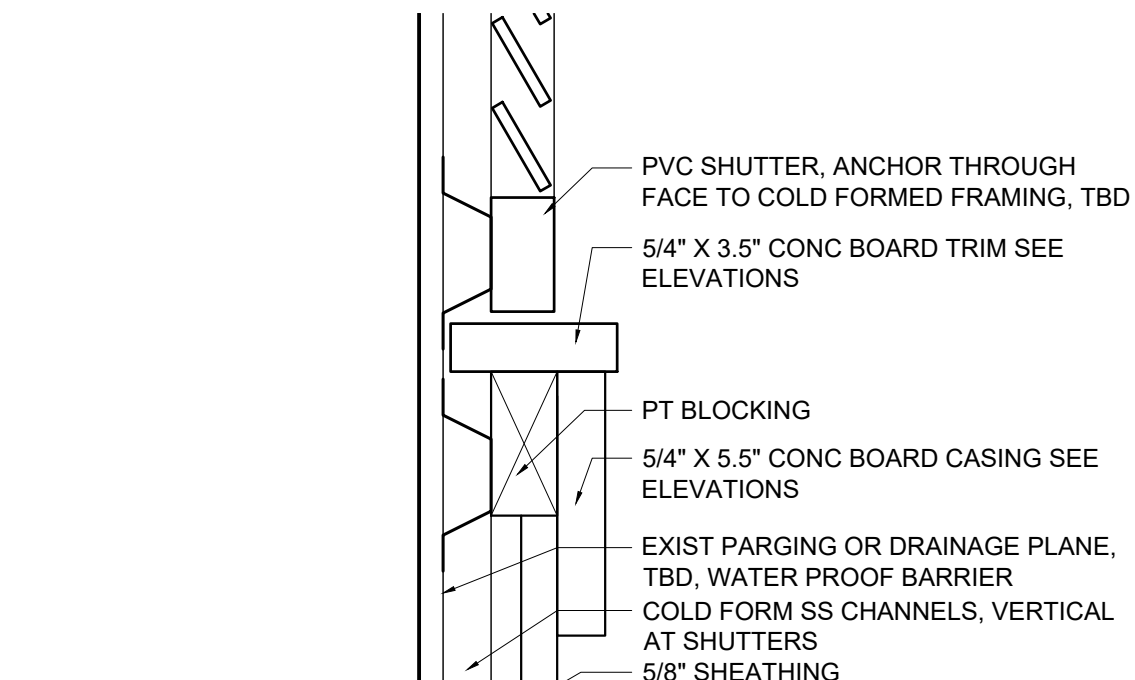

16 SHUTTER SILL  
3"=1'-0"

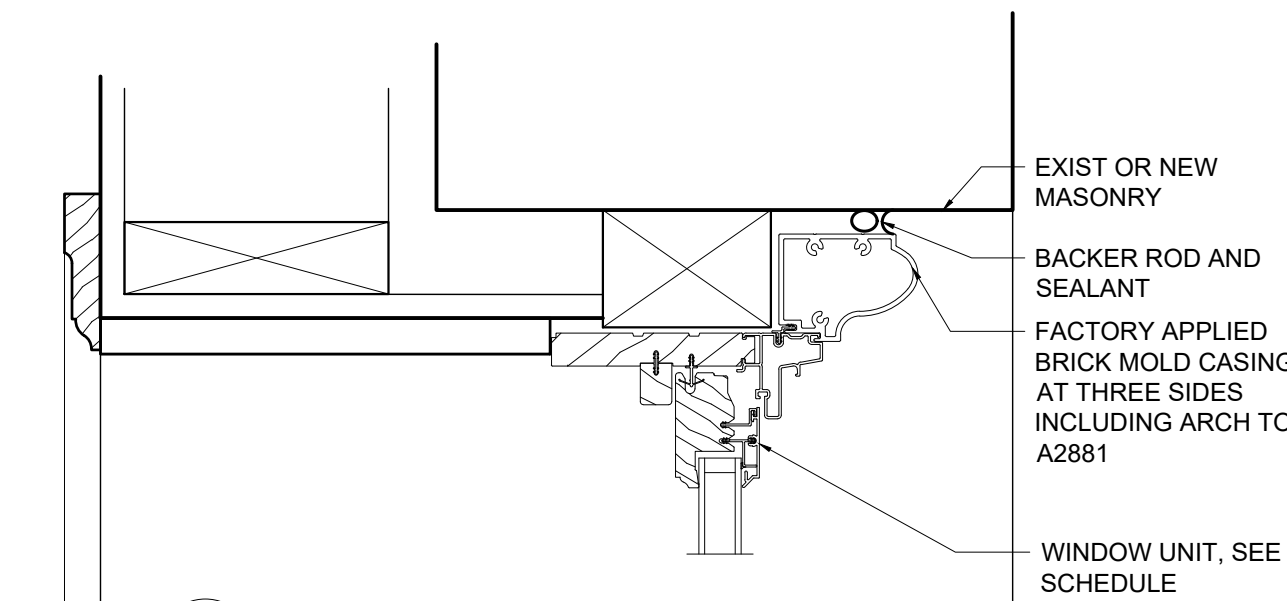

11 HEAD AT MO - CURVED & FLAT  
3"=1'-0"

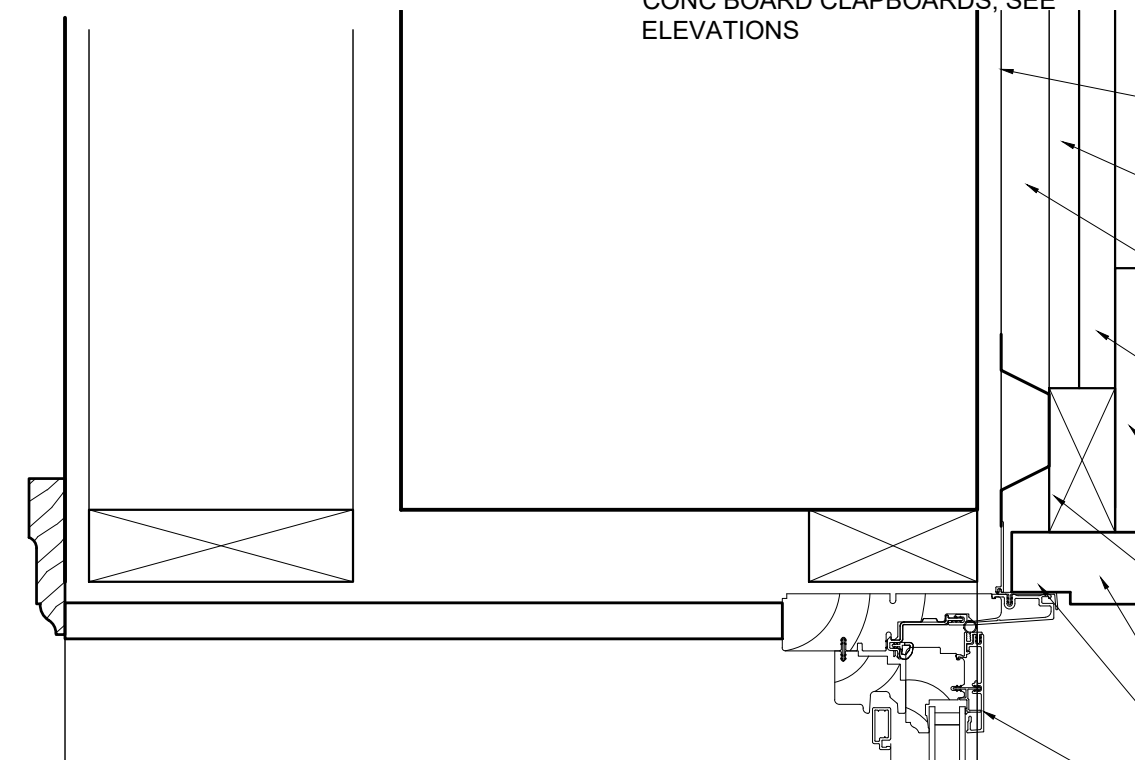

15 HEAD AT TYPE N & O  
3"=1'-0"

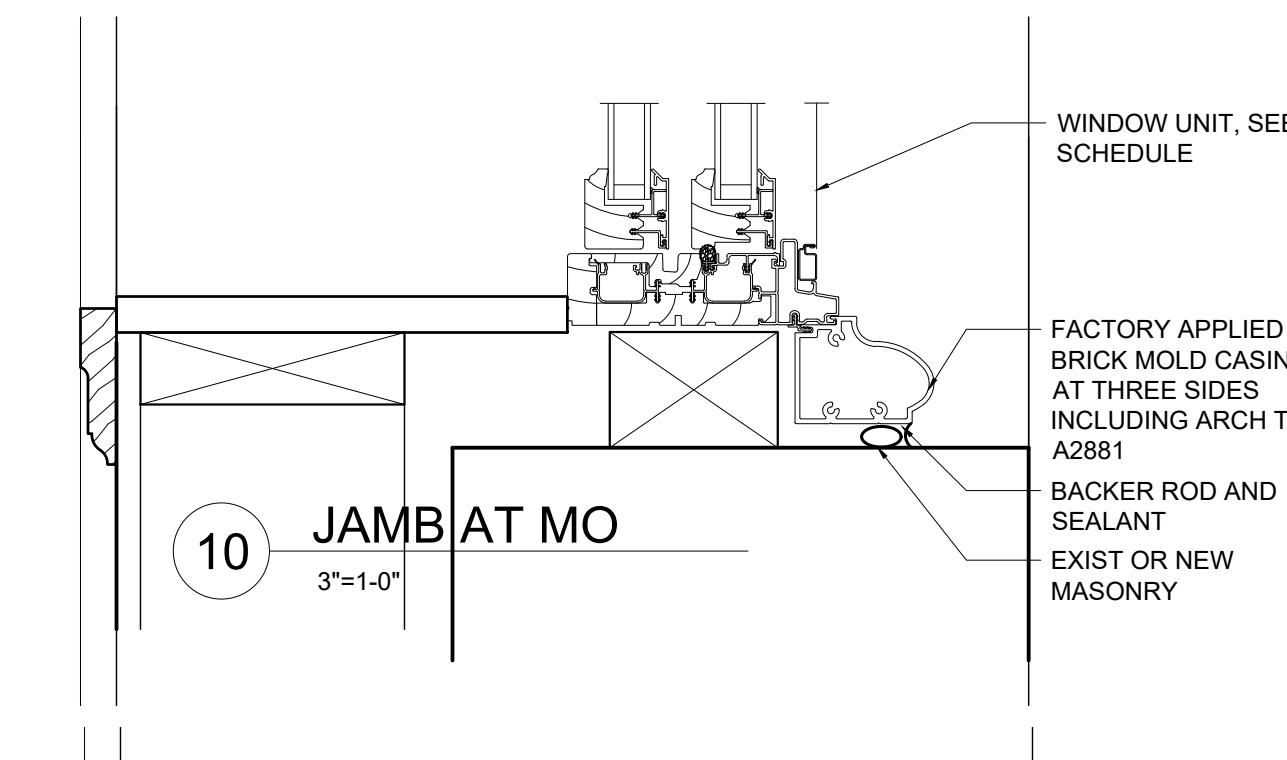

10 JAMB AT MO  
3"=1'-0"

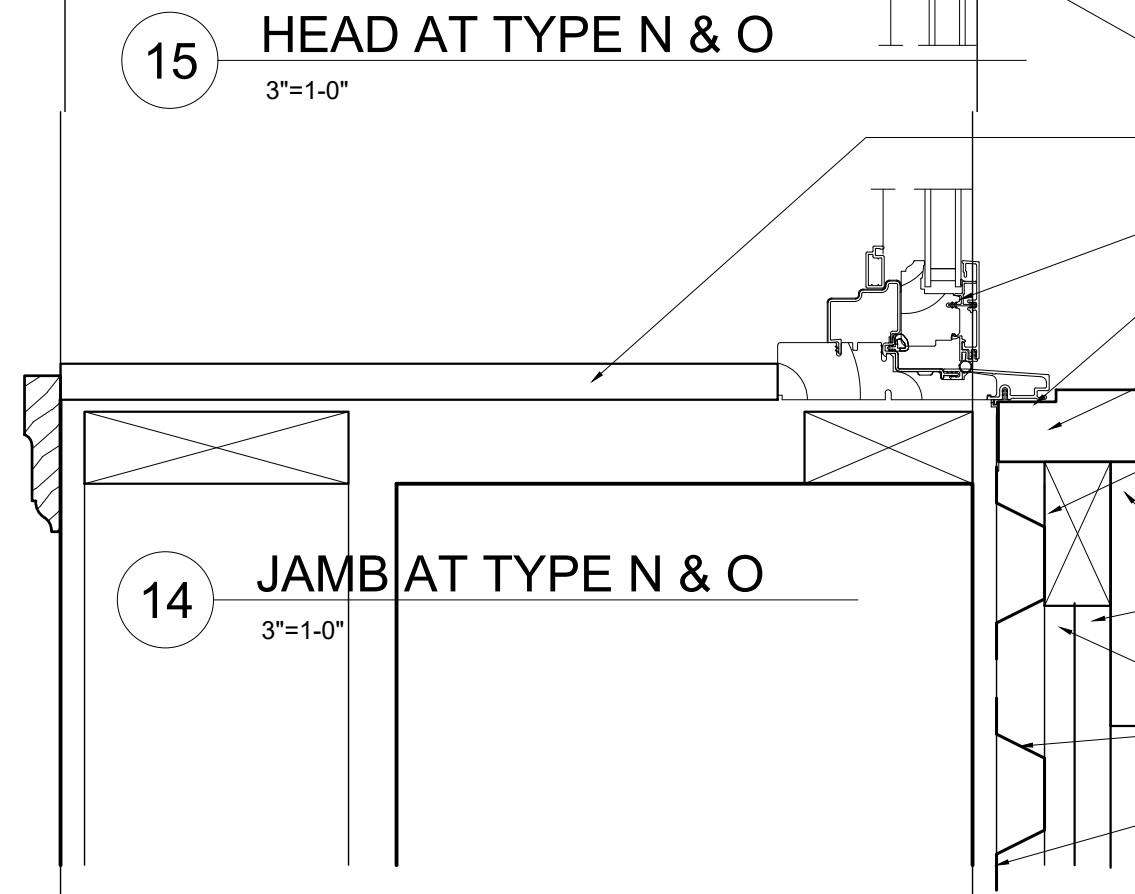

14 JAMB AT TYPE N & O  
3"=1'-0"

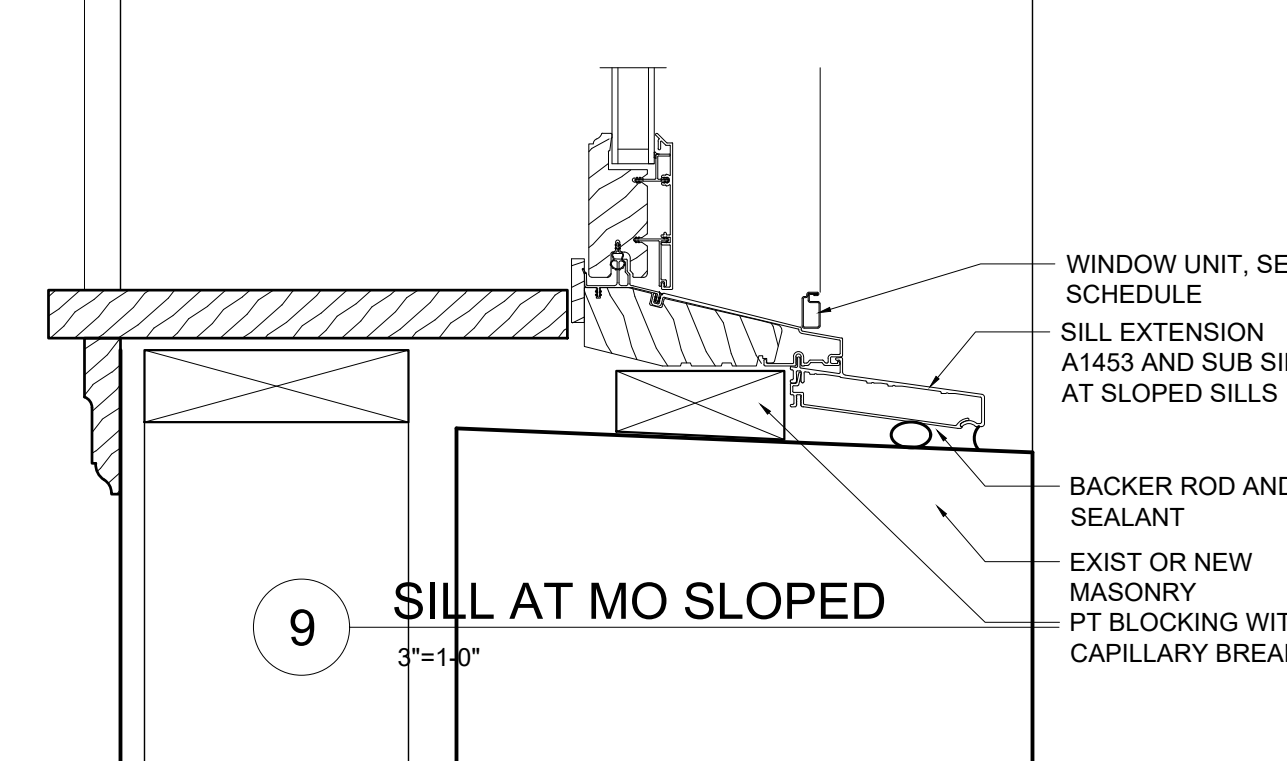

9 SILL AT MO SLOPED  
3"=1'-0"

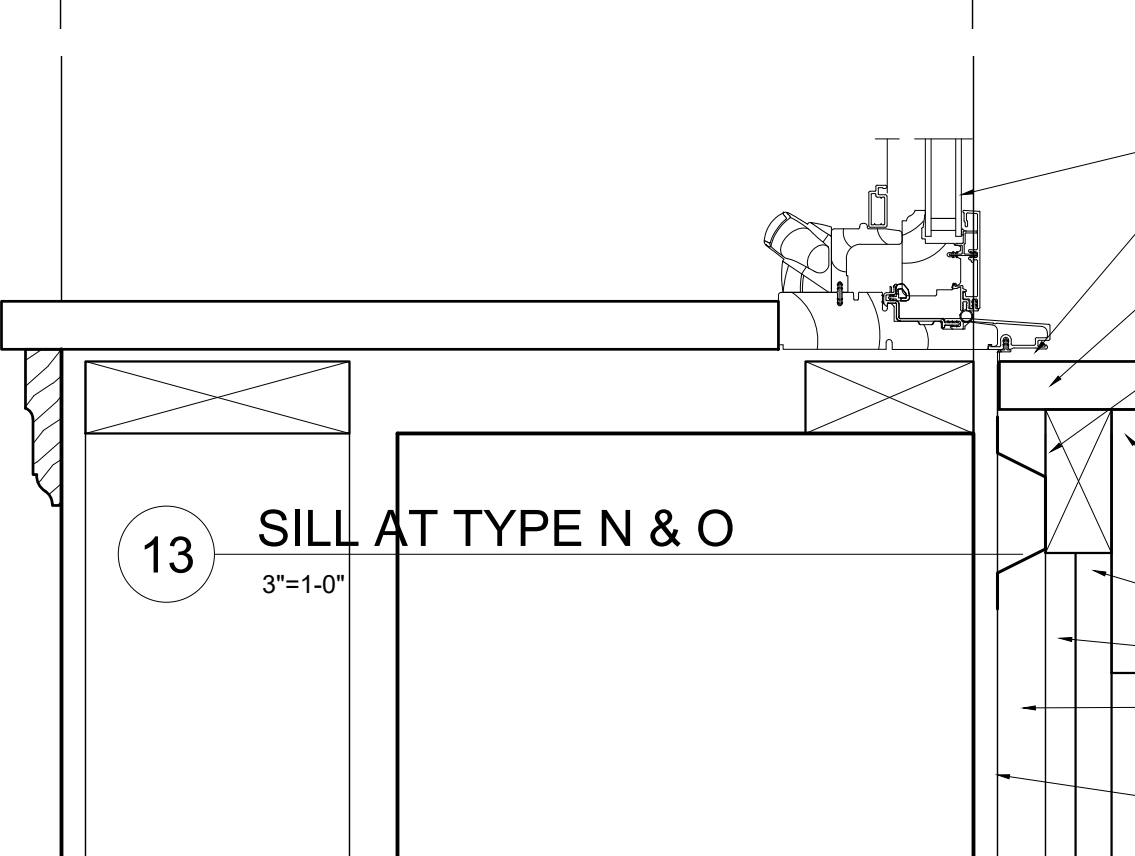

13 SILL AT TYPE N & O  
3"=1'-0"

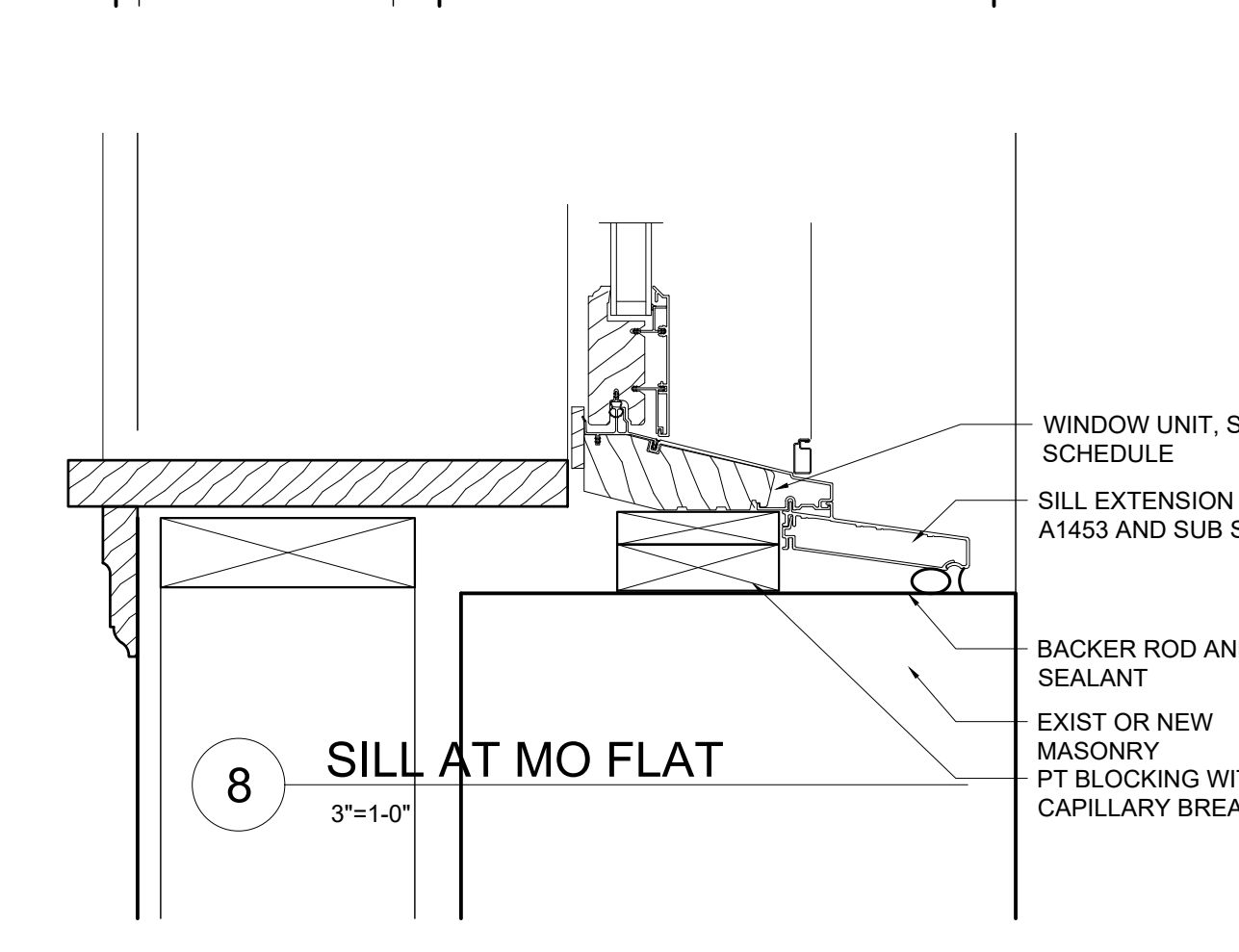

8 SILL AT MO FLAT  
3"=1'-0"

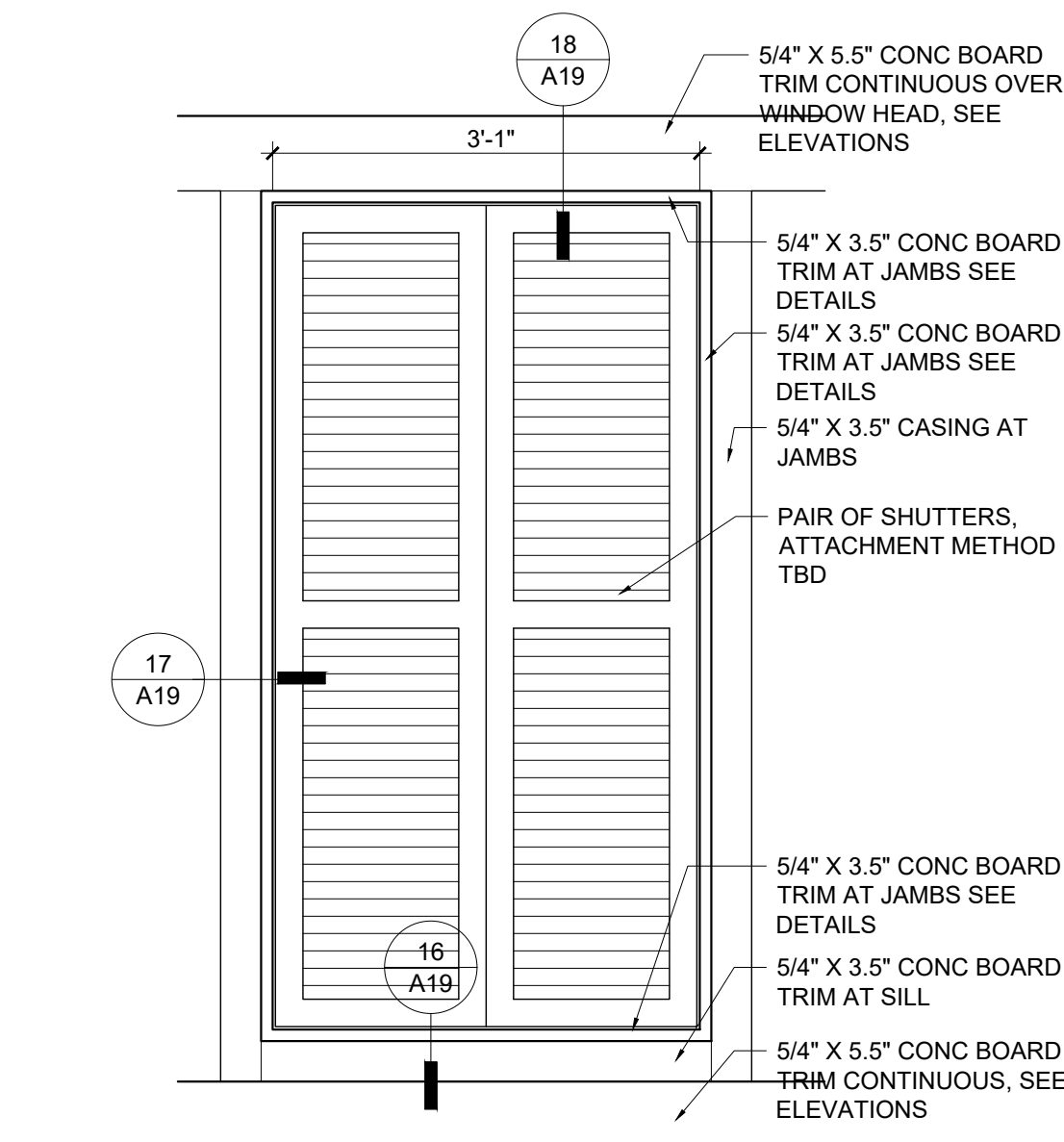

4 SHUTTER ELEVATION  
3/4"=1'-0"

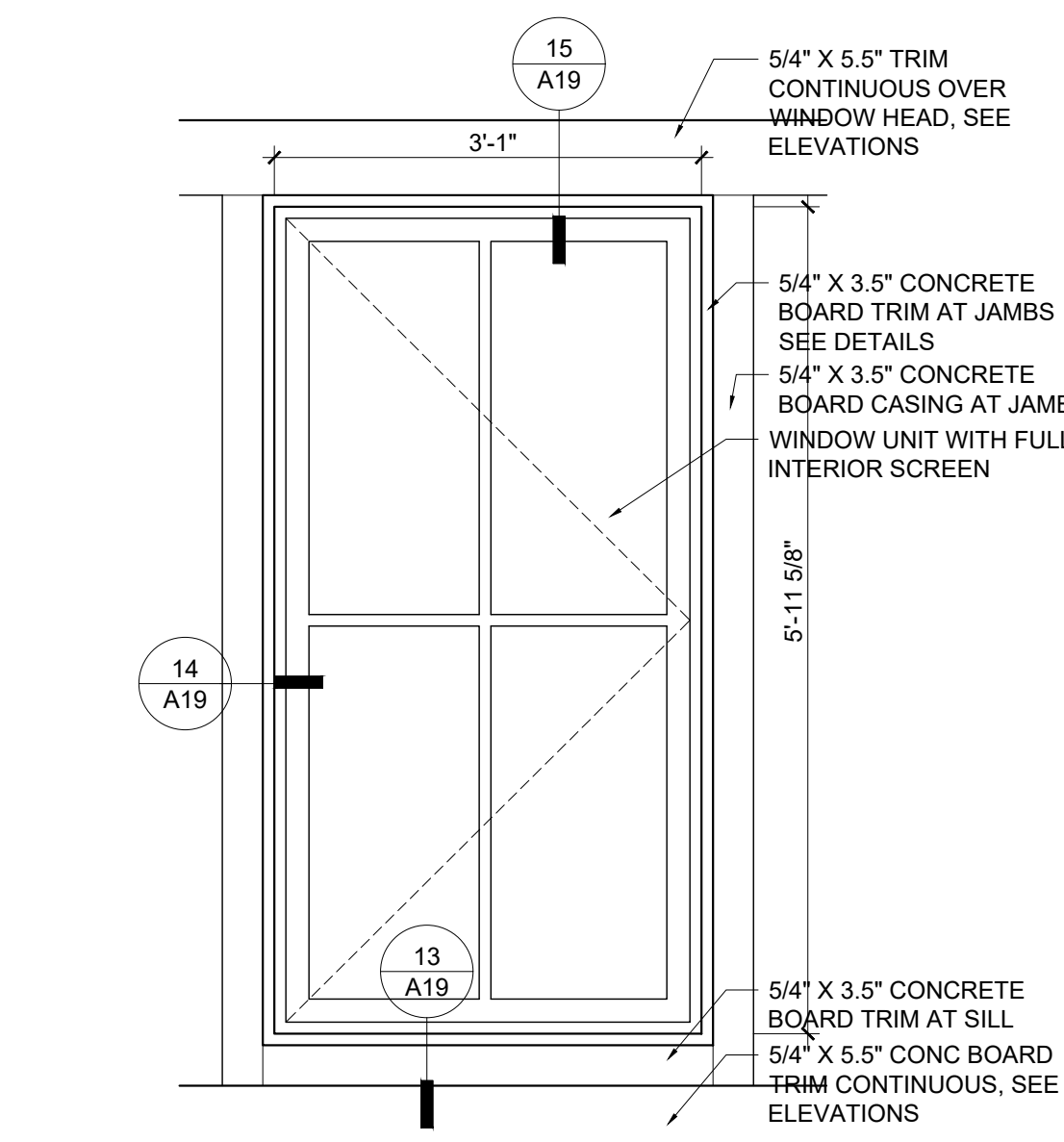

3 WINDOW TYPE O & N  
DETAIL ELEVATION  
3/4"=1'-0"

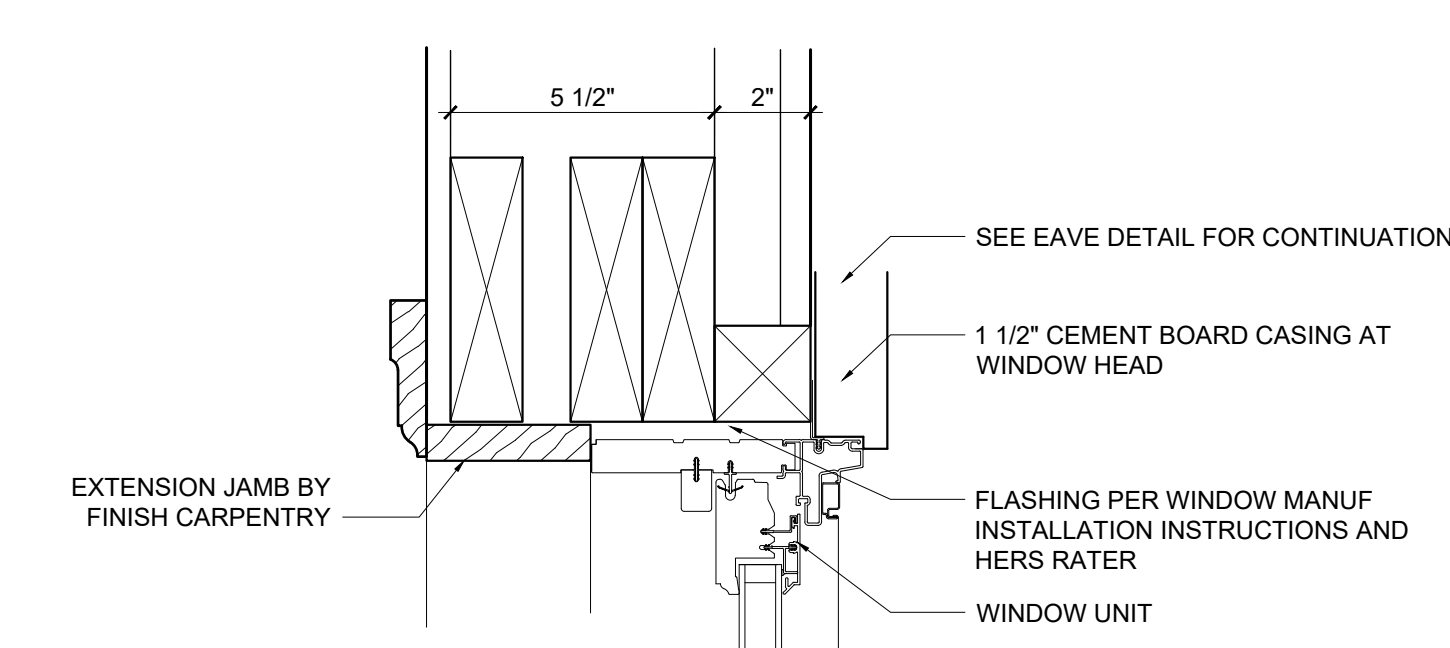

7 HEAD IN FRAMED OPENING  
3"=1'-0"

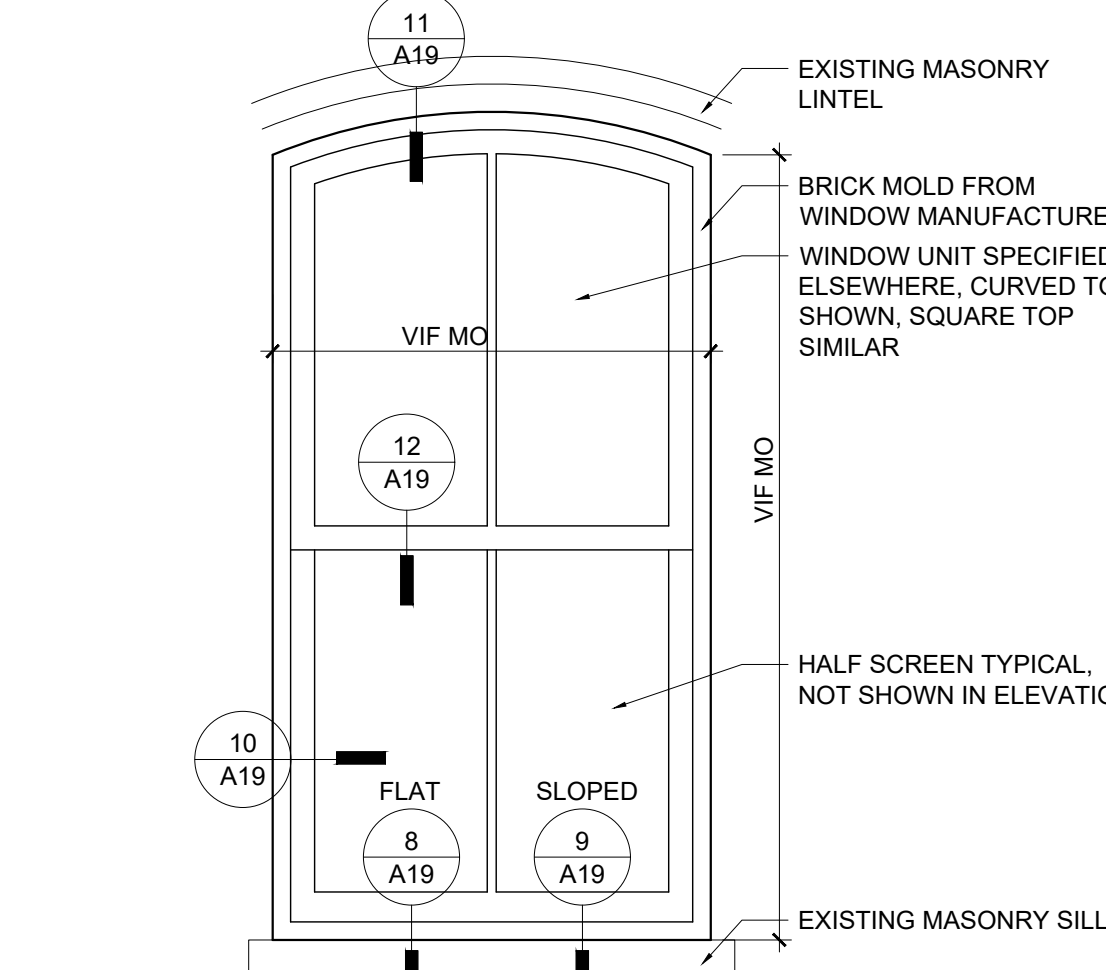

2 SQUARE & ARCH TOP  
WINDOWS IN MASONRY OPENING  
3/4"=1'-0"

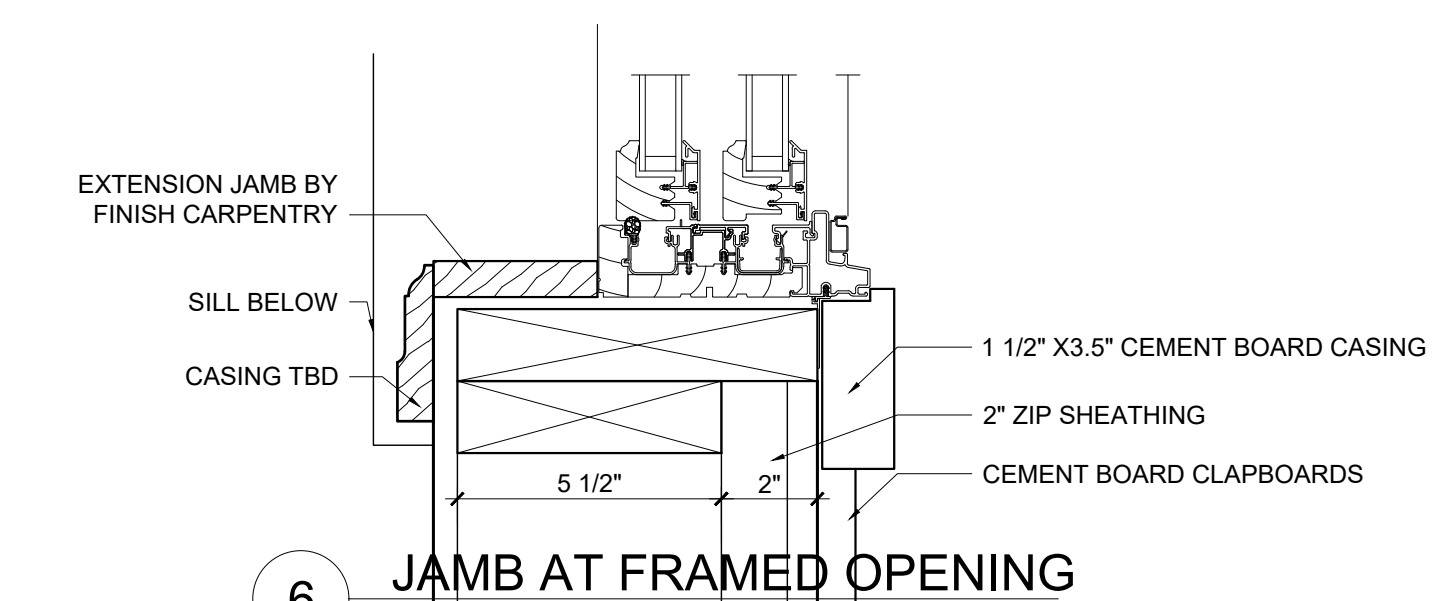

6 JAMB AT FRAMED OPENING  
3"=1'-0"

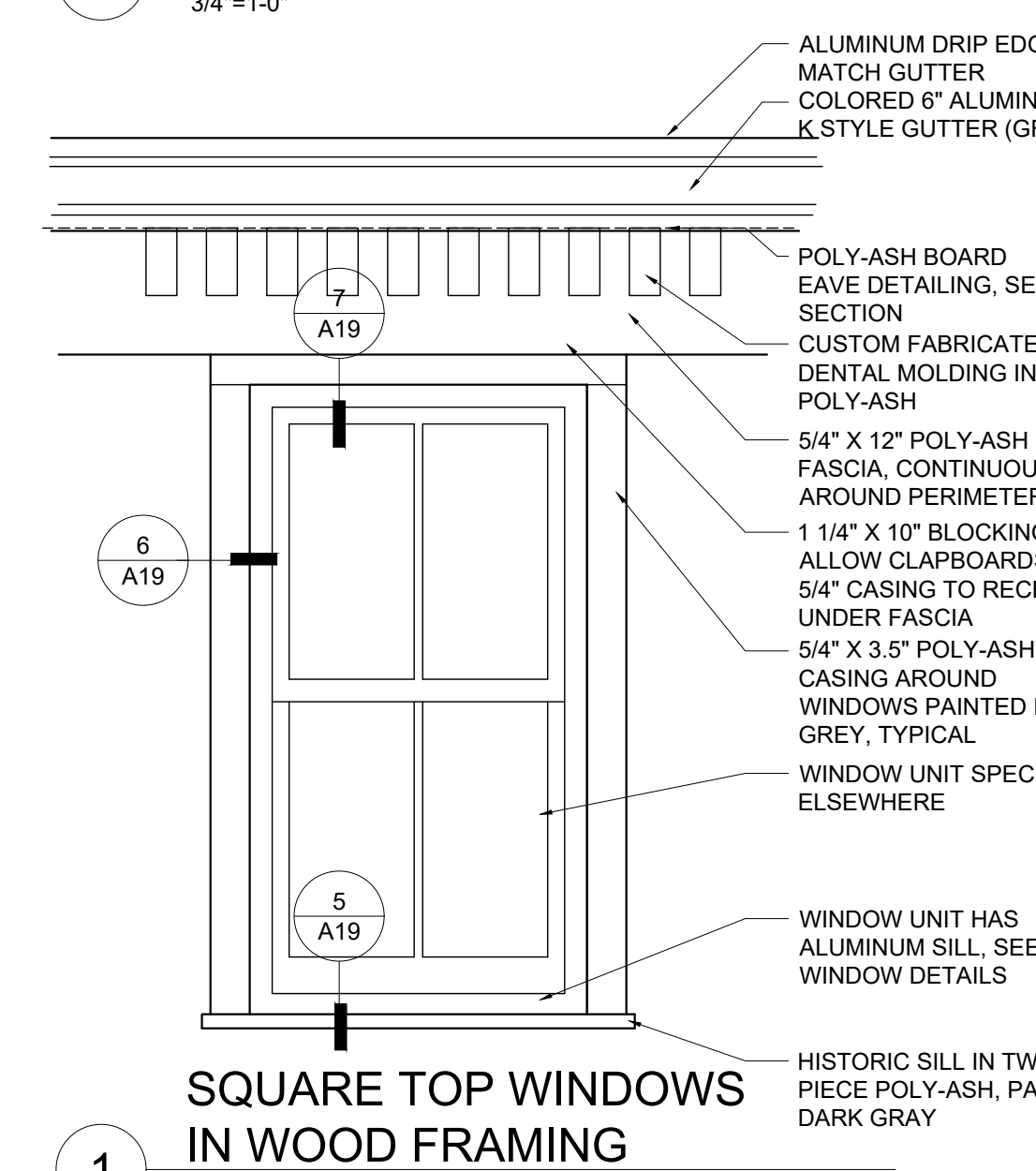

1 SQUARE TOP WINDOWS  
IN WOOD FRAMING  
3/4"=1'-0"

DO NOT SCALE THE DRAWINGS. THESE DRAWINGS MAY NOT BE TO SCALE DUE TO REPRODUCTIONS TO FACILITATE PRINTING

