

WELDED PARKING METER POST AND FLANGE

DATE: AUG. 23, 1971 REV: NOV. 17, 1982 REV: APR. 16, 1986 REV: FEB. 2, 2001 REV: OCT. 28, 2014

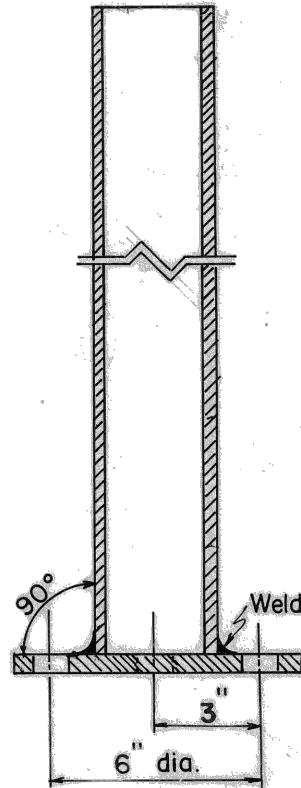

SECTION A-A

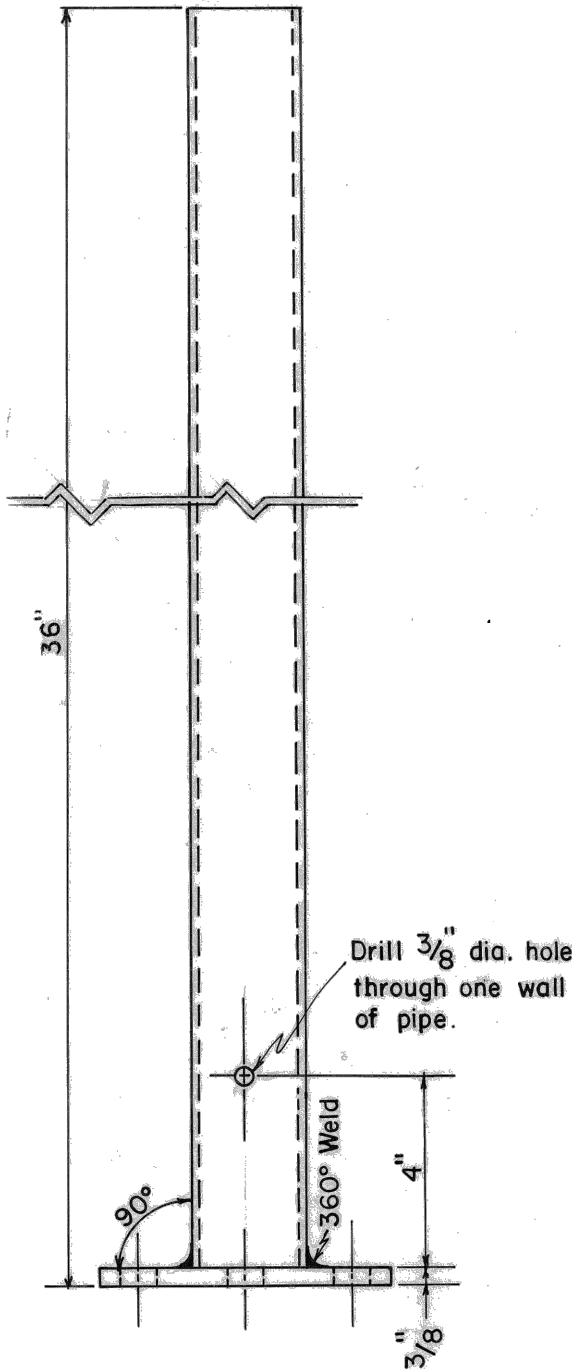
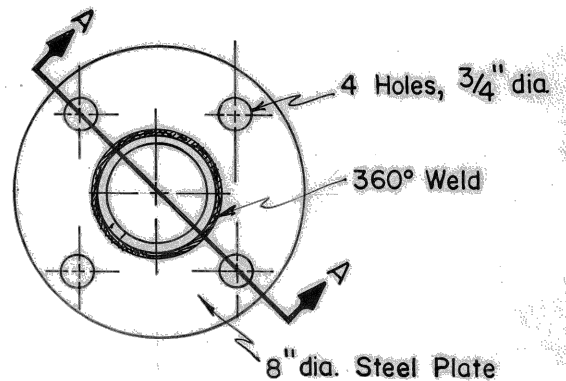

NOTES:

1. Pipe to be cut square.
2. Meter posts to be reamed inside and deburred outside on the top end.
3. After welding, steel plate flange to be hot dipped galvanized.
4. Meter posts to be 2" Schedule 40 Galvanized Pipe.

Not to Scale

A104